



## QSB Features

- Low-cost, easy-to-use USB (Type A) adapter
- QSB-S and QSB-D reads single-ended or differential quadrature, PWM and analog encoders
- QSB-M adds four analog and four digital I/O pins and 1 channel stepper motor control to QSB-S
- Reads quadrature count rate up to 6 MHz
- USB port provides power for adapter and connected encoder
- Free downloadable software works with Windows and Linux



## QSB Product Description

The QSB is a low-cost USB data acquisition device. The QSB-S and QSB-D count quadrature and index signals from incremental, PWM, and analog encoders. The QSB-M provides digital I/O and acts as a 1-channel stepper/motor controller.



- **QSB-S** - One single-ended quadrature, PWM, or Analog encoder interface
- **QSB-D** - One differential quadrature, PWM or Analog encoder interface and 1-bit of digital I/O
- **QSB-M** - One single-ended quadrature, PWM or Analog encoder interface; 4-bits of digital I/O or 2-bits of digital I/O and 1-channel stepper motor control (step/direction)

The QSB plugs into any USB (Type A) port on a Windows or Linux machine and is bus-powered. US Digital provides free software, examples, and documentation needed to use the QSB. The QSB appears as a COM serial port to the PC, so any application that can read/write the COM port can be used to control the QSB.

The QSB-S and QSB-D can be used with the “QuickCheck (<https://www.usdigital.com/support/resources/downloads/software/qsb-software/>)” app to verify the CPR of an encoder with index quickly.

**WARNING:** This product can cause exposure to substances, such as *phthalate plasticizers*, known to the State of California to cause cancer and reproductive harm. For more information, go to [oehha.ca.gov/proposition-65](https://oehha.ca.gov/proposition-65) (<https://oehha.ca.gov/proposition-65>).

## Mechanical Drawings

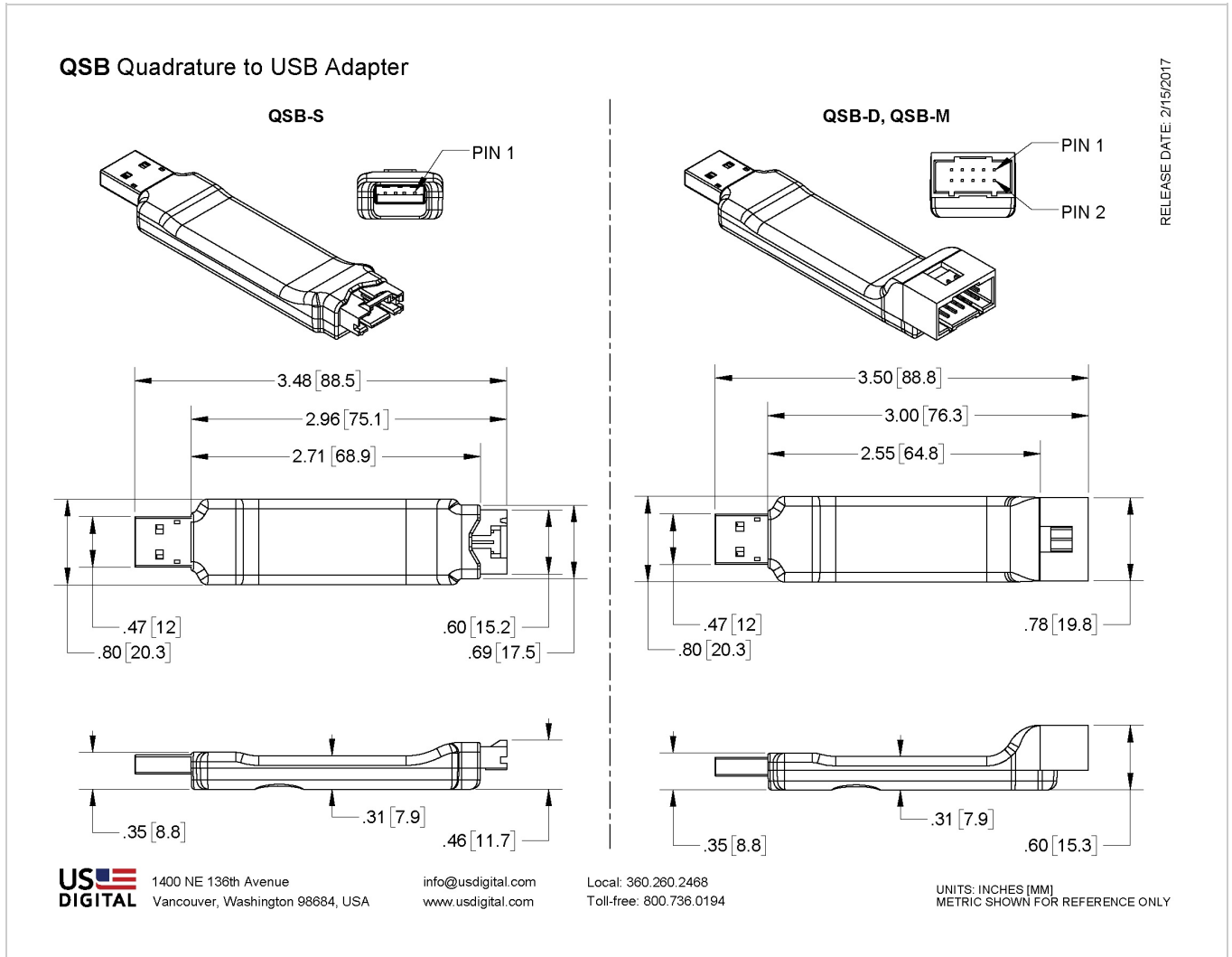

## Specifications

### ENVIRONMENTAL

PARAMETER	MIN.	MAX.	UNITS
Operating Temperature	0	70	C
Electrostatic Discharge, -S, -M Versions (IEC 61000-4-2)		± 15	kV
-D Version (HBM)		± 2	kV



## ELECTRICAL

PARAMETER	MIN.	TYP.	MAX.	UNITS
Supply Voltage (1)	4.75	5.00	5.25	V
Supply Current (QSB device only)		52		mA
Supply Current (External devices) (2)			450	mA

(1) Voltage is regulated by USB port

(2) USB port capable of supplying 500mA maximum

## PIN-OUTS

### QSB-S Pinout

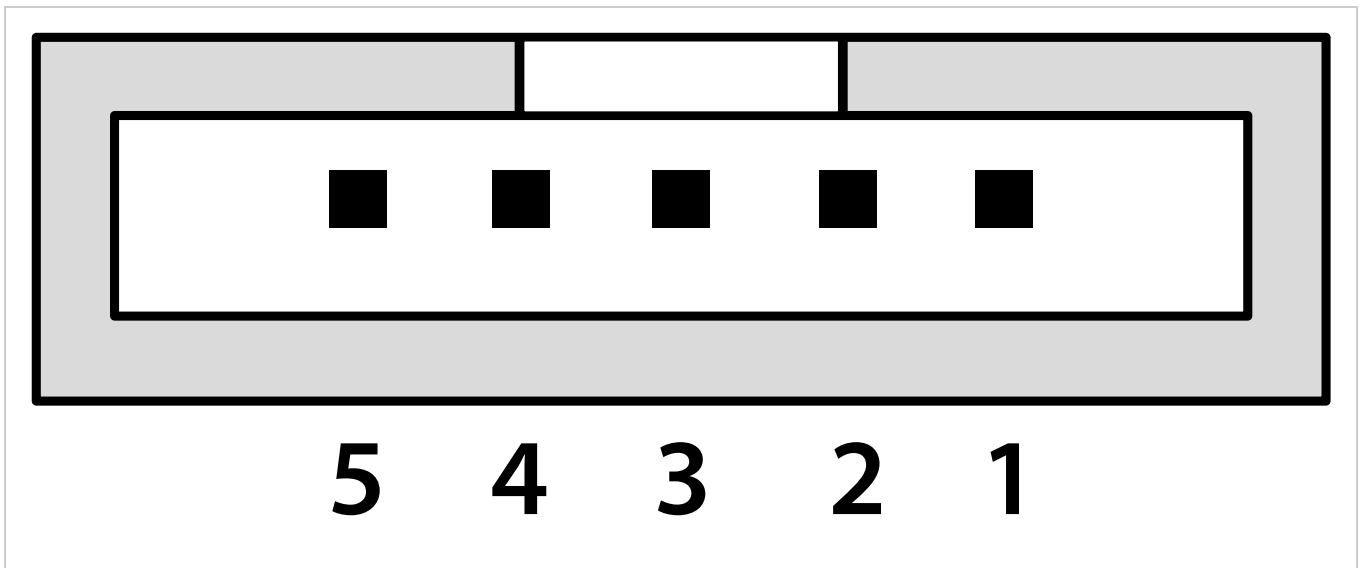

Pin	5-Pin Connector
1	Ground
2	Index
3	A Channel or EAN0 or PWM0
4	+5 Volts
5	B Channel

### Notes:

- Pin 3 EAN0 is an A/D input designed for the MAE3-A10 and MA3-A10 analog output encoders. It can be used as a generic 10-bit A/D input (0-5V range).



- Pin 3 PWM0 is a pulse width modulation input designed for the 10 or 12-bit PWM output of the MA3/MAE3 encoders

## QSB-D, QSB-M Pinout

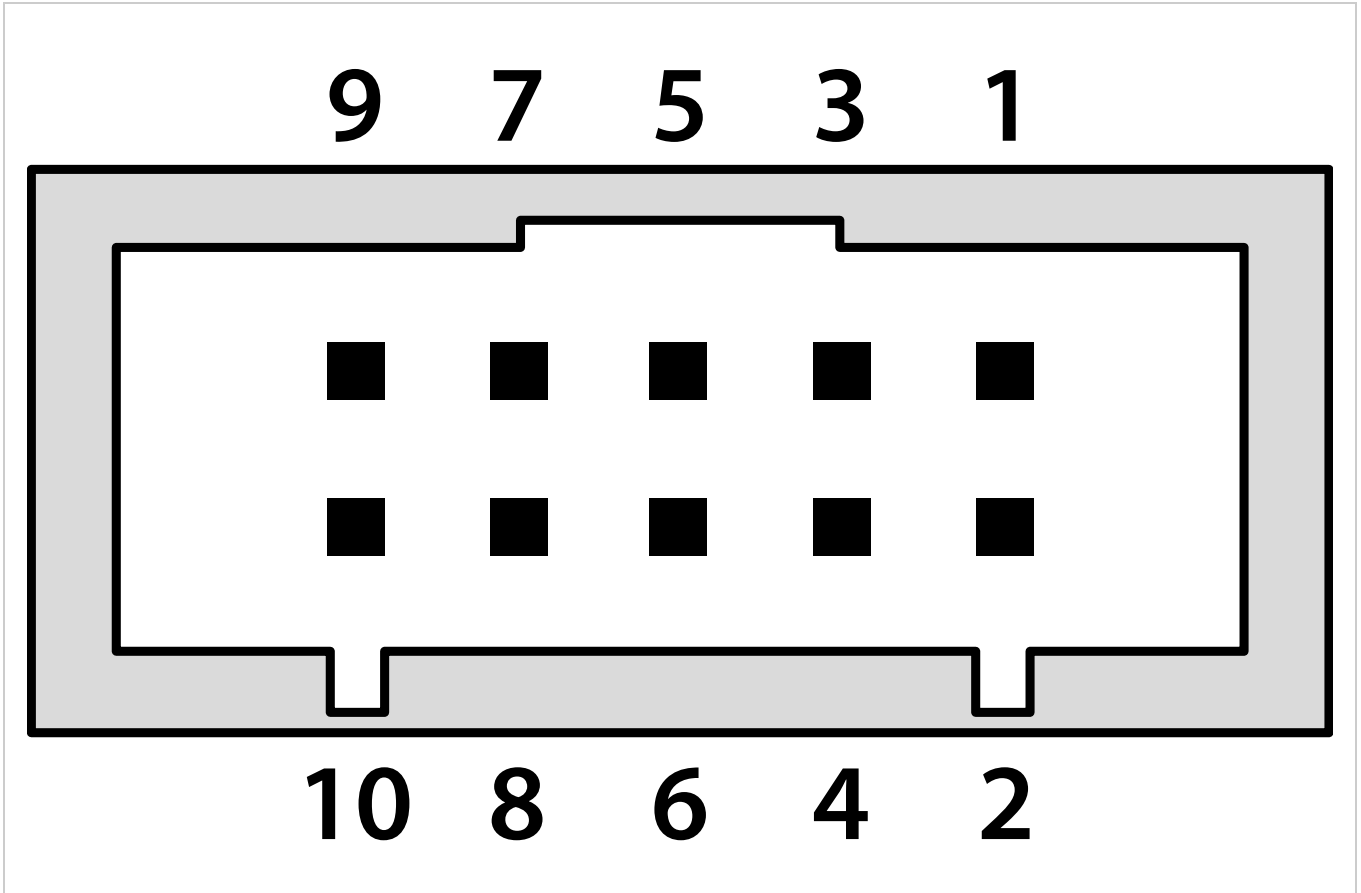



Pin	10-pin Connector QSB-D	10-pin Connector QSB-M
1	Digital I/O Channel 0	Digital I/O Channel 0
2	Ground	Ground
3	Index-	Digital I/O Channel 1 or Motor Step
4	Index+	Index
5	A-/PWM0-	Digital I/O Channel 2 or Motor Direction
6	A+ or EAN0 or PWM0+	A or EAN0 or PWM0
7	+5 Volts	+5 Volts
8	No connection	+5 Volts
9	B-	Digital I/O Channel 3
10	B+	B

Notes:

- Pin 6 EAN0 is an A/D input designed for the MAE3-A10 and MA3-A10 analog output encoders. It can be used as a generic 10-bit A/D input (0-5V range).
- Pin 6 PWM0+/PWM0- is a differential pulse width modulation input designed for the 10 or 12-bit PWM output of the MA3/MAE3 encoders.



## ENCODER INTERFACE (QSB-D, QSB-M, QSB-S)

Quadrature Encoder Input Frequency	0	6	MHz	
PWM Encoder Input Frequency (1)	250	1000	Hz	
Encoder Single-Ended Interface				
-Low Input	-0.5	2.1	V	
-High Input	2.8	5.5	V	
Encoder Differential Interface				
-Differential Voltage	0.2	5.5	V	
-Input Voltage Range	-0.5	5.5	V	
Analog Encoder Input				
-Voltage Range	0	5	V	
-DC Input resistance	4.8	6.3	9	kOhm
-Bandwidth	0	3000	Hz	

(1): The PWM mode is designed specifically to operate with US Digital's MA3/MAE3. The EA-D-L-10 interface device is required for use with the QSB-D.

## DIGITAL I/O (ALL VARIANTS)

PARAMETER	MIN.	TYP.	MAX.	UNITS
Digital Input Voltage	0	5	24.5	V
Positive-going Input Voltage Threshold	1.5		2.5	V
Negative-going Input Voltage Threshold	0.83		1.82	V
Input Voltage Hysteresis	0.33		1.1	V
Digital High Output Voltage (Note 1)	4.5	4.7	5.0	V
Digital Low Output Voltage (Note 1)	0	0		V

Note 1: Output can be externally pulled up to 24V through a load if desired. Open drain MOSFET pulldown capable of 1.0 A max. continuous current. See digital output port circuits below. When driving inductive loads, add an external diode to protect the QSB from damage caused by large voltage transients.

Digital Input Port Circuit:

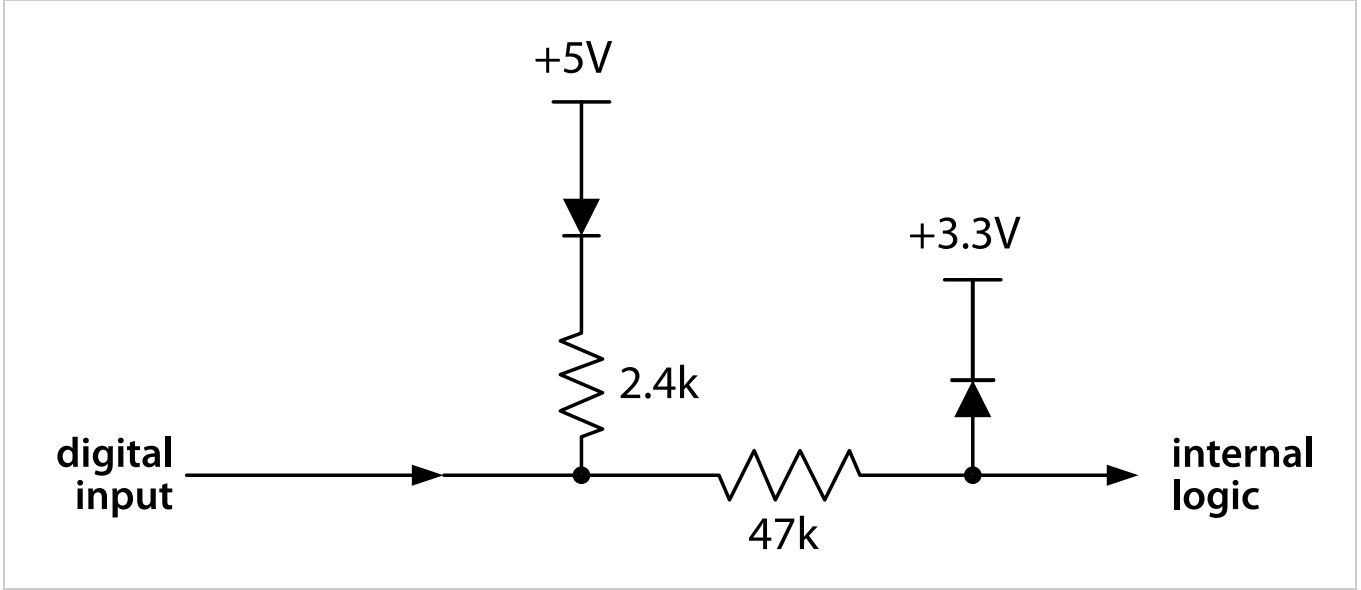

Digital Output Port Circuit:

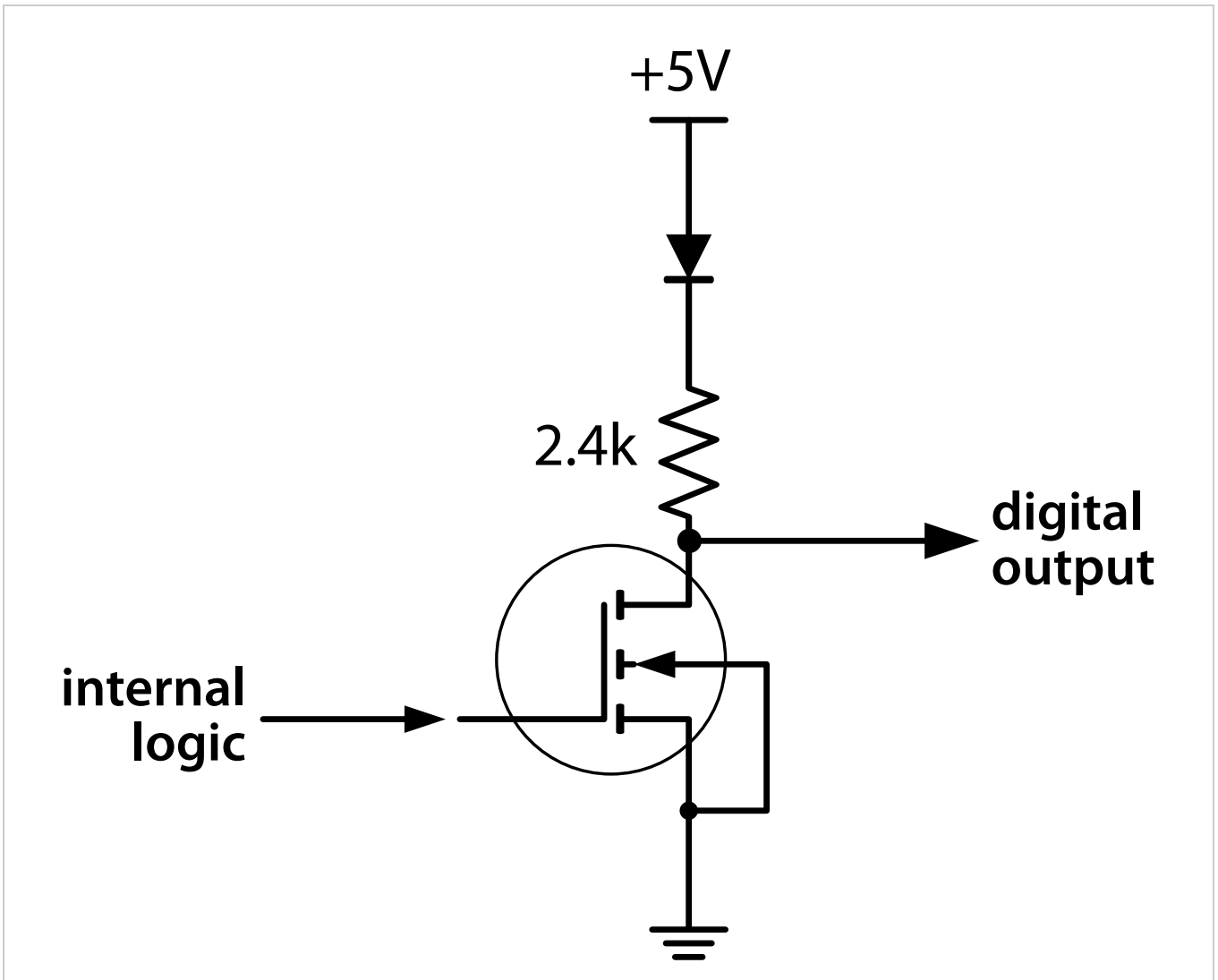



## STEPPER MOTOR CONTROL (QSB-M ONLY)

The speed and direction of a single stepper motor can be controlled using the QSB-M in conjunction with a stepper motor driver, such as the US Digital MD3. Two of the four digital I/O port pins can be configured to have motor step/direction functionality or normal digital I/O.

See the **QSB Command List** (<https://www.usdigital.com/support/resources/reference/user-guides/qsb-command-list/>) document for detailed information on the QSB's motor control commands.

## COMMAND INTERFACE

See the **QSB Command List** (<https://www.usdigital.com/support/resources/reference/user-guides/qsb-command-list/>) document for detailed information on the commands.

## SOFTWARE FIELD UPGRADE

The QSB firmware can be easily upgraded using the "QSB Firmware Updater" program that is available on the QSB Software (<https://www.usdigital.com/support/resources/downloads/software/qsb-software/>) page. There may be periodic upgrades to the QSB firmware that can be loaded as needed by a customer. The firmware upgrades typically take less than 30 seconds.

## Notes

- Cables and connectors are not included and must be ordered separately.
- US Digital® warrants its products against defects in materials and workmanship for two years. See complete warranty (<https://www.usdigital.com/company/warranty>) for details.

## Configuration Options

QSB

Interface

D (Differential & I/O)

M (Single-Ended & I/O)

S (Single-Ended)

**PLEASE NOTE: This chart is for informational use only.** Certain product configuration combinations are not available. Visit the QSB product page (<https://www.usdigital.com/products/QSB>) for pricing and additional information.