

# E6 Assembly Instructions for Shafts > 0.394" (10mm)

## Step 1:

Place encoder base onto mounting surface. Slip centering tool over the shaft and into the center hole of the base. While holding pressure on the centering tool, tighten mounting screws. Remove centering tool.

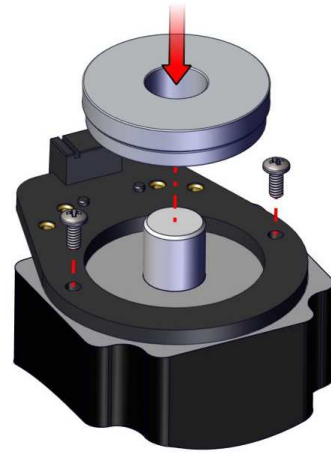

## Step 2:

Push the spacer tool onto the bottom section of the hubdisk assembly. Slip hubdisk assembly onto shaft and slide down until spacer tool bottoms out against encoder base.

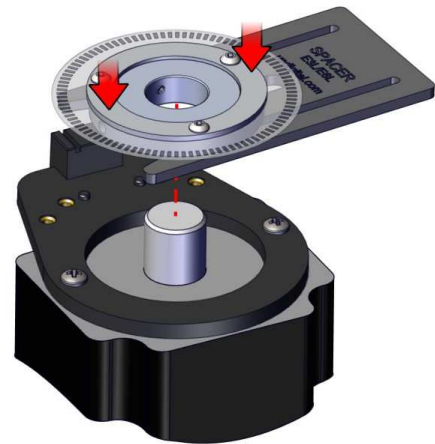

## Step 3:

Tighten set screw with provided hex wrench while pressing down on hub. Remove spacer tool.

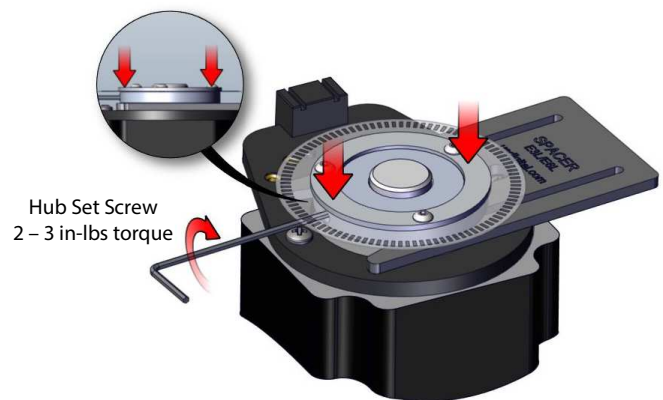

# E6 Assembly Instructions for Shafts > 0.394" (10mm)

## Step 4:

Slip optical module into position until the two alignment pins slip into holes of module (thick side of module towards bottom). Secure with two 4-40 x 1/2" screws (supplied).

### Differential version only:

Press line driver onto module pins until it reaches the end of its motion.

### Caution!

To avoid injury make sure that the line driver is held properly (as shown) during installation, module pins are sharp!

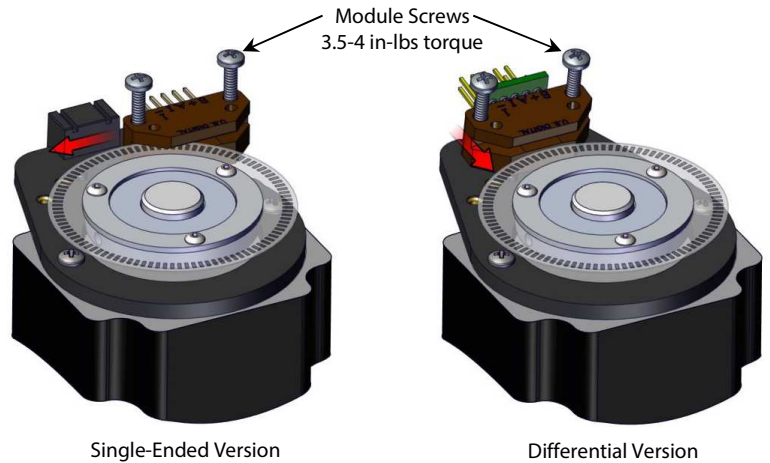
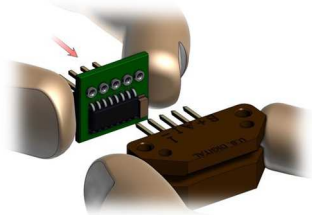

## Step 5:

Place cover over assembly and secure with two 4-40 5/8" flat head screws (supplied).

