

H3 Features

- Ball-bearing option tracks to 10,000 RPM
- 2-channel quadrature, TTL squarewave outputs
- 3rd channel index option available on some resolutions
- 64 to 10,000 cycles per revolution (CPR)
- 256 to 40,000 pulses per revolution (PPR)
- Wide operating temperature
- Single +5VDC supply

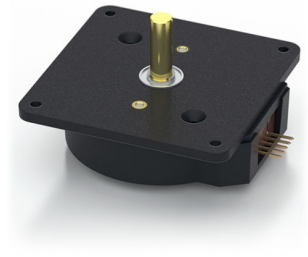

H3 Product Description

The H3 series ball-bearing optical shaft encoder has a glass-filled polymer enclosure. This non-contacting rotary to digital converter is designed to provide digital feedback information. The H3 is fully assembled with a brass shaft, two 1/4 in. ID by 1/2 in. OD ball bearings and a mounting plate. The mounting plate comes with 4 mounting holes for #2 - #4 size screws.



The H3 is designed to drive cables up to 10 feet long. For longer cable lengths, adding a PC4

(<https://www.usdigital.com/products/accessories/interfaces/cable-drivers/pc4/>) / PC5 (<https://www.usdigital.com/products/accessories/interfaces/cable-drivers/pc5/>) differential line driver is recommended. A connection to the H3 series encoder is made through a 5-pin standard connector. The mating connectors are available from US Digital with several cable options and lengths.

Mechanical Drawings

H3 Ball Bearing Optical Shaft Encoder

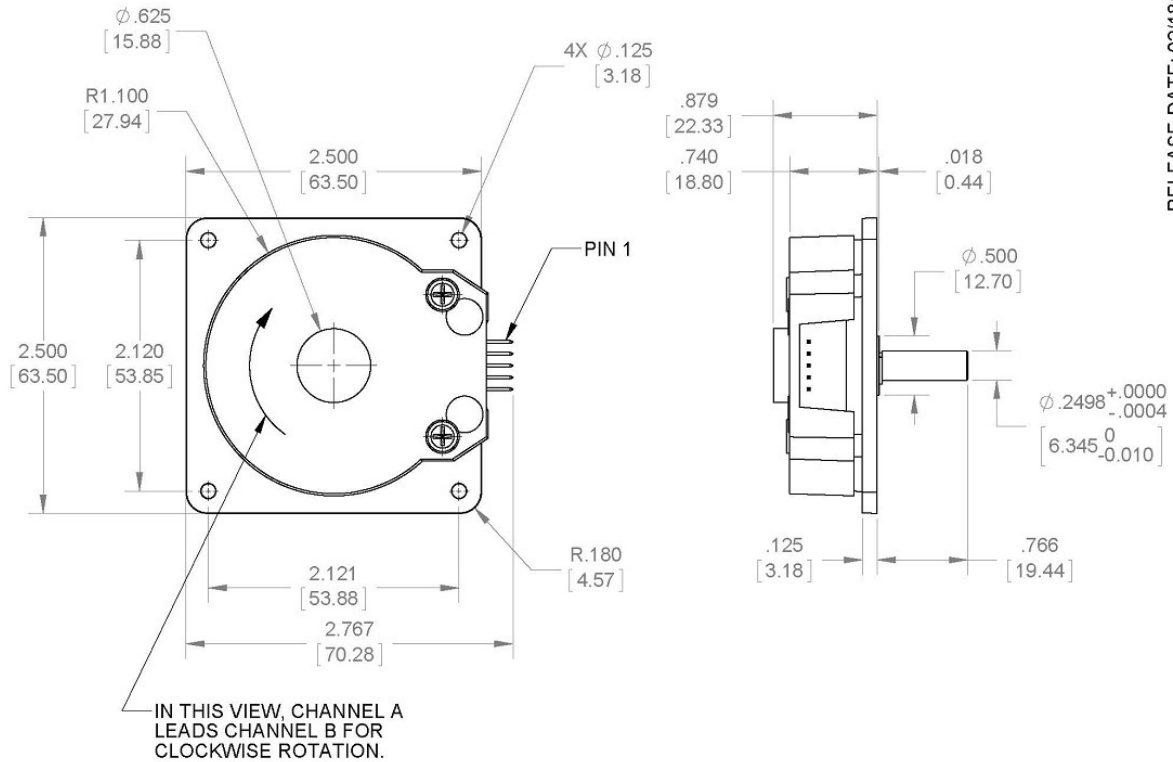

RELEASE DATE: 02/18/2014

US DIGITAL 1400 NE 136th Avenue
Vancouver, Washington 98684, USA

info@usdigital.com
www.usdigital.com

Local: 360.260.2468
Toll-free: 800.736.0194

UNITS: INCHES [MM]
METRIC SHOWN FOR REFERENCE ONLY

Specifications

ENVIRONMENTAL

PARAMETER	VALUE	UNITS
Operating Temperature, CPR < 2000	-40 to 100	C
Operating Temperature, CPR ≥ 2000	-25 to 100	C
Electrostatic Discharge, IEC 61000-4-2	± 4	kV
Vibration (10Hz to 2kHz, sinusoidal)	20	G
Shock (6 milliseconds, half-sine)	75	G



MECHANICAL

PARAMETER	VALUE
Max. Acceleration	100000 rad/sec ²
Max. Shaft Speed (mechanical)	10000 RPM (1)
Max. Shaft Torque	0.05 in-oz
Max. Shaft Loading	2 lbs.
Bearing Life	life in millions of revs = $(90/P)^3$ where P = radial load in pounds.
Weight	2.69 oz.
Max. Shaft Runout	0.006 in. T.I.R.
Mounting Plate Screw Torque	(#2-56) 2-3
Moment of Inertia	0.001 oz-in-s ²
Technical Bulletin TB1001 - Shaft and Bore Tolerances	Download (https://www.usdigital.com/support/resources/reference/technical-docs/technical-bulletins/shaft-and-bore-tolerances-tb1001/)

(1) The maximum speed due to electrical considerations is dependent on the CPR. See the EM1 (<https://www.usdigital.com/products/encoders/incremental/modules/em1/>) and EM2 (<https://www.usdigital.com/products/encoders/incremental/modules/em2/>) product pages.

PHASE RELATIONSHIP

B leads A for clockwise shaft rotation, and A leads B for counterclockwise rotation when viewed from the shaft side of the encoder.

ELECTRICAL

- Specifications apply over the entire operating temperature range.
- Typical values are specified at Vcc = 5.0Vdc and 25°C.
- For complete details, see the EM1 (<https://www.usdigital.com/products/encoders/incremental/modules/em1/>) and EM2 (<https://www.usdigital.com/products/encoders/incremental/modules/em2/>) product pages.



H3 Ball Bearing Optical Shaft Encoder

PARAMETER	MIN.	TYP.	MAX.	UNITS	CONDITIONS
Supply Voltage	4.5	5.0	5.5	V	
Supply Current		27	33	mA	CPR < 1000, no load
		54	62	mA	CPR ≥ 1000 and < 3600, no load
		72	85	mA	CPR ≥ 3600, no load
Low-level Output			0.5	V	I _{OL} = 8mA max., CPR < 3600
			0.5	mA	I _{OL} = 5mA max., CPR ≥ 3600
		0.05		mA	no load, CPR < 3600
		0.25		mA	no load, CPR ≥ 3600
High-level Output	2.0			V	I _{OH} = -8mA max., CPR < 3600
	2.0			V	I _{OH} = -5mA max., CPR ≥ 3600
		4.8		V	no load, CPR < 3600
		3.5		V	no load, CPR ≥ 3600
Output Current Per Channel	-8		8	mA	CPR < 3600
	-5		5	mA	CPR ≥ 3600
Output Rise Time		110		nS	CPR < 3600
		50		nS	CPR ≥ 3600
Output Fall Time		35		nS	CPR < 3600
		50		nS	CPR ≥ 3600

PIN-OUT

PIN	DESCRIPTION
1	Ground
2	Index
3	A channel
4	+5VDC power
5	B channel

Notes

- Cables and connectors are not included and must be ordered separately.
- US Digital® warrants its products against defects in materials and workmanship for two years. See complete warranty (<https://www.usdigital.com/company/warranty>) for details.



Configuration Options

H3	CPR (Cycles Per Revolution)	Index	Housing
	64	IE (<i>Index</i>)	D (<i>Default</i>)
	100	NE (<i>Non-Index</i>)	
	200		
	400		
	500		
	512		
	1000		
	1024		
	1800		
	2000		
	2048		
	2500		
	3600		
	4000		
	4096		
	5000		
	7200		
	8000		
	8192		
	10000		

PLEASE NOTE: This chart is for informational use only. Certain product configuration combinations are not available. Visit the H3 product page (<https://www.usdigital.com/products/H3>) for pricing and additional information.