



**The PS-5 is no longer available for purchase.**

## PS-5 Product Description

The PS-5 is a 10W regulated switching power supply that outputs 5 VDC @ 2 A. The power supply covers voltage inputs ranging from 90 VAC to 264 VAC. The typical efficiency is 65%. The PS-5 has overvoltage, overload, and short circuit protection.

The output connector is a 2.1 mm circular plug attached to a 48-inch-long cable. The power supply plugs directly into a standard US 120 VAC receptacle.

## Specifications

### ELECTRICAL SPECIFICATIONS

Input Voltage	90 VAC to 264 VAC
Input Frequency	47 Hz to 63 Hz
Output Voltage	5 VDC $\pm$ 5%
Output Current	2.0 A
Line Regulation	$\pm$ 1 %
Efficiency	65%
Ripple & Noise	$\pm$ 50 mV maximum



# PS-5 REGULATED SWITCHING 5 V (2 A) POWER SUPPLY

## ENVIRONMENTAL/SAFETY SPECS.

Operating Temperature	0 C to 40 C
Storage Temperature	-30 C to 80 C
Relative Humidity	5% to 95% RH, non-condensing
Protection	Overvoltage, Overload, and short-circuit
Safety Standards	UL1950, CB (per EN60950)
EMI	FCC Class B, CISPR 22 (EN55022) Class B
MTBF	> 100 kHours (25 C) per MIL-HDBK-217F

## OUTPUT VOLTAGE VS. LOAD

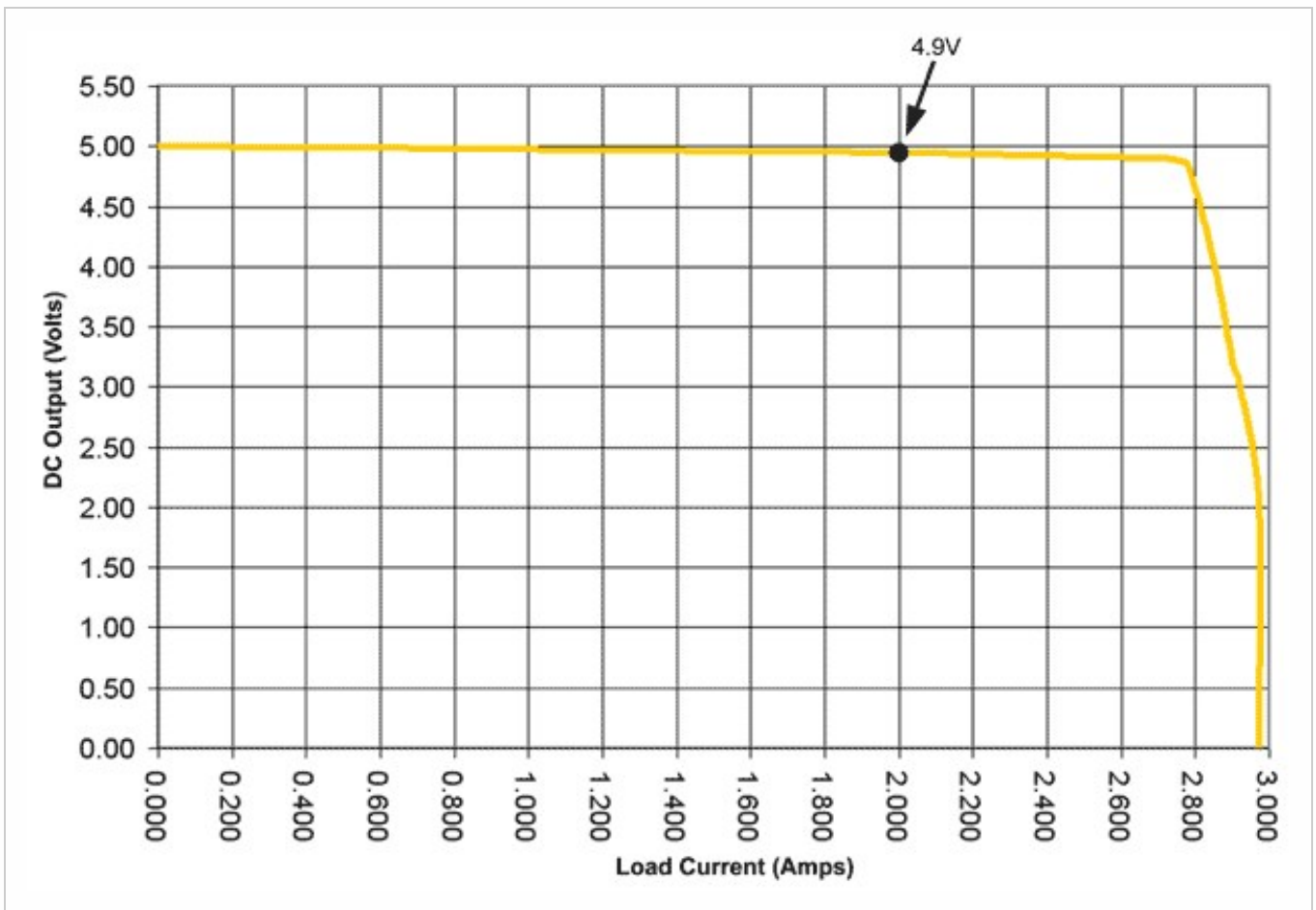



## CONNECTOR

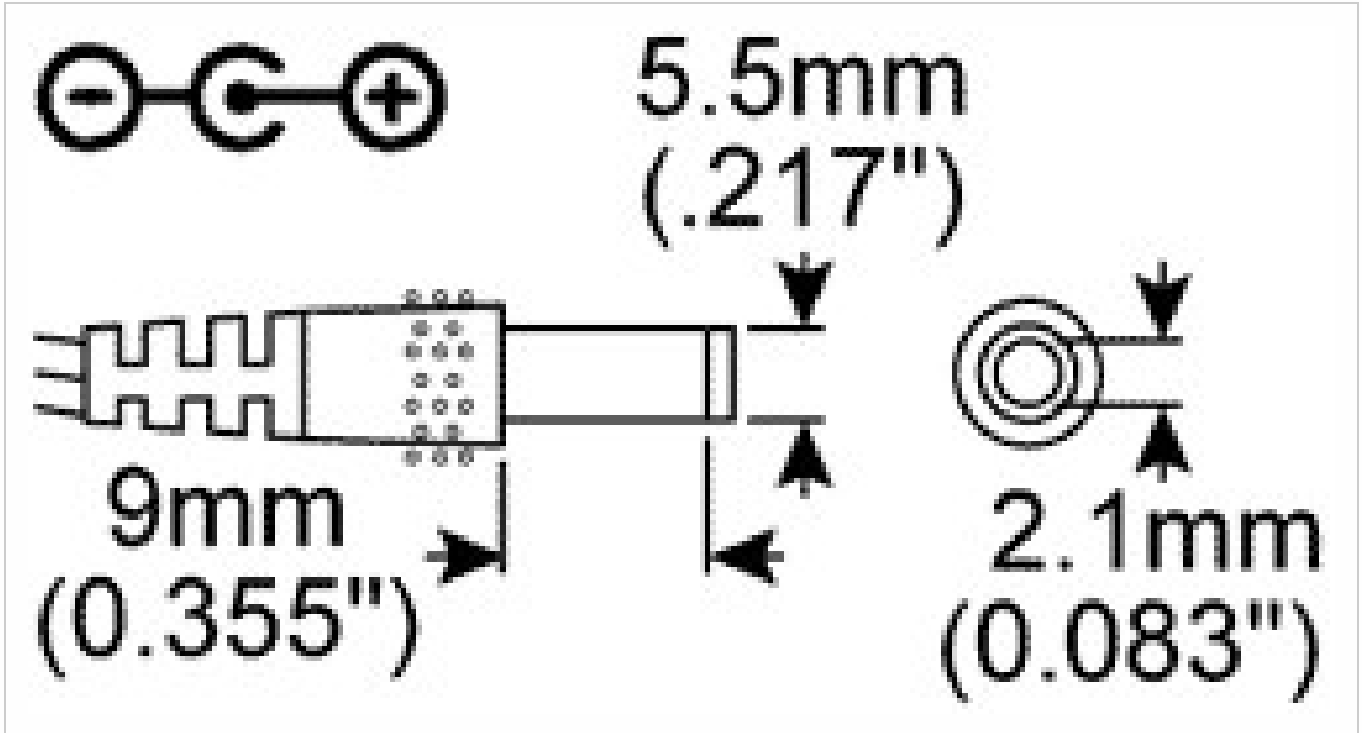

## Notes

- Cables and connectors are not included and must be ordered separately.
- US Digital® warrants its products against defects in materials and workmanship for two years. See complete warranty (<https://www.usdigital.com/company/warranty>) for details.

## Configuration Options

PS-5

**PLEASE NOTE: This chart is for informational use only.** Certain product configuration combinations are not available. Visit the PS-5 product page (<https://www.usdigital.com/products/PS-5>) for pricing and additional information.