

A2 Features

- Sleeve bushing or ball bearing versions
- 12-bit resolution and resolution field programmable from 2 to 4,096 codes per revolution (3,600 factory default)
- Full 360-degree range, 7 msec update time
- Low power drain of 18.5 mA max., and 2.5 mA in sleep mode
- Field programmable parameters such as setting zero position point (demo software available for download below)
- EEPROM stores downloadable parameters
- 9,600 baud default data rate adjustable up to 115K baud
- 12-bit analog voltage output option (0 to +3.599 volts factory default setting. Field programmable up to 0 to +4.095 volts)
- Multi-turn mode (note: power must be maintained to prevent reset to zero)
- -25 to 70 degrees C. operating temperature



A2 Product Description

The A2 optical encoder is a 12-bit absolute rotary encoder which reports a shaft angle within a single 360-degree rotation of a shaft. Unlike incremental, sometimes called relative, style encoders, the A2 provides true (absolute) shaft position eliminating the need for a home or zero cycle after a supply voltage power cycle. The A2 communicates over a RS 485 style serial bus utilizing US Digital's SEI (Serial Encoder Interface), which allows for simple, quick and convenient networking of multiple SEI devices on a single network. PLCs, motion controllers, and computers can also reside on the SEI bus by using US Digital's SEI to USB interface device. For complete information about the SEI bus, please refer to the SEI Absolute Encoder Communications Protocol (<https://www.usdigital.com/support/resources/reference/user-guides/sei-absolute-encoder-communications-protocol/>) webpage.



The A2 is also available with an optional analog output. The analog output option provides a maximum voltage range of 0 to 4.095 volts with 12-bit resolution. The output voltage can be scaled by simple SEI commands to provide user-defined voltage ranges. From the factory, the analog output voltage is set to 0 to 3.599 VDC range. Please note that with the A2 analog output option, only one device may reside on an SEI bus.

Mechanical Drawings

US DIGITAL | A2 Absolute Optical Shaft Encoder

A2 Absolute Optical Shaft Encoder Ball Bearing Version

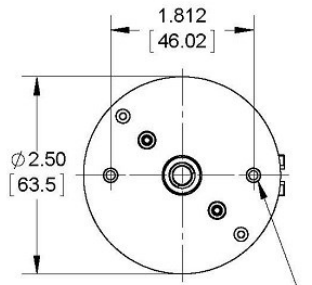

2X #4-40 MOUNTING HOLES
.220 [5.59] MAX SCREW INSERTION

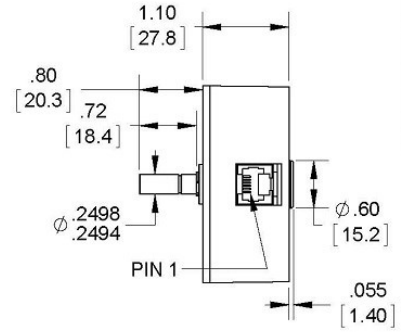

RELEASE DATE: 07/17/2014

E-OPTION COVER (REAR SHAFT EXTENSION)

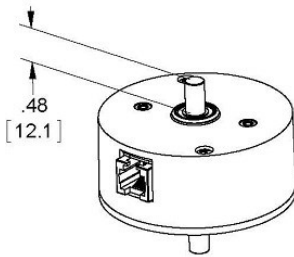

M-OPTION BASE (MOUNTING PLATE)

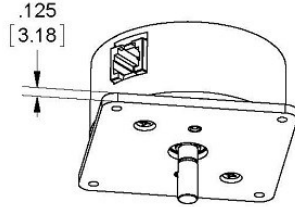
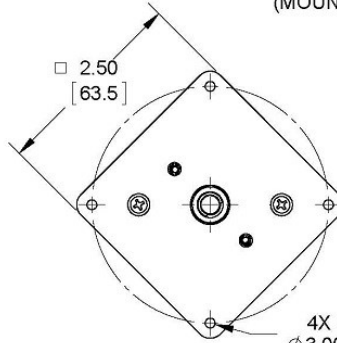

US DIGITAL 1400 NE 136th Avenue
Vancouver, Washington 98684, USA

info@usdigital.com
www.usdigital.com

Local: 360.260.2468
Toll-free: 800.736.0194

UNITS: INCHES [MM]
METRIC SHOWN FOR REFERENCE ONLY

A2 Absolute Optical Shaft Encoder Bushing Version

RELEASE DATE: 07/17/2014

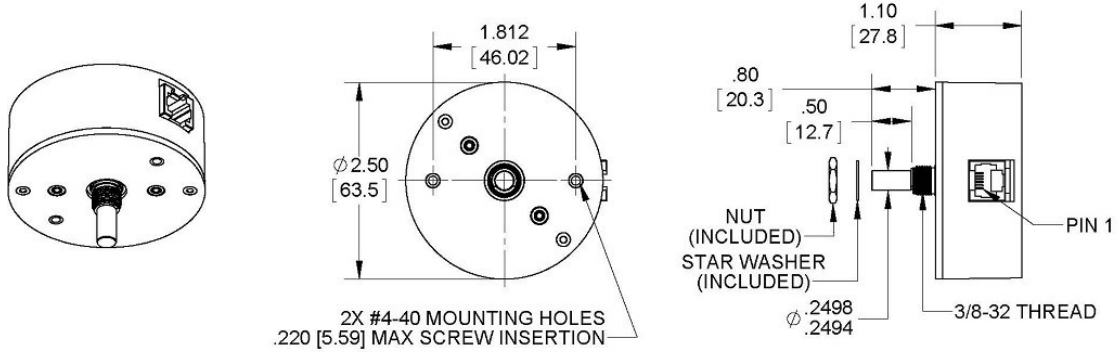

M-OPTION BASE (MOUNTING PLATE)

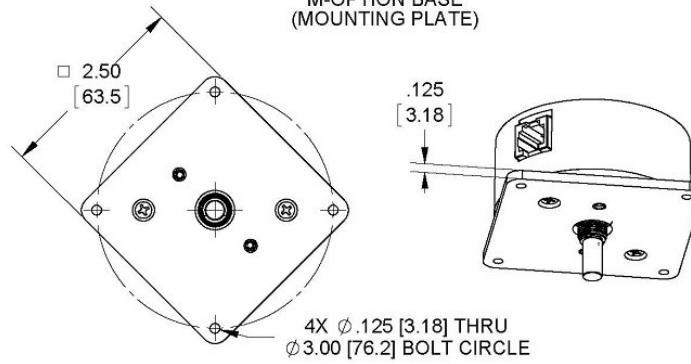

US DIGITAL 1400 NE 136th Avenue
Vancouver, Washington 98684, USA

info@usdigital.com
www.usdigital.com

Local: 360.260.2468
Toll-free: 800.736.0194

UNITS: INCHES [MM]
METRIC SHOWN FOR REFERENCE ONLY

Specifications

ENVIRONMENTAL

PARAMETER	VALUE	UNITS
Operating Temperature	-25 to 70	C
Vibration (5Hz to 2kHz)	20	G
Electrostatic Discharge, IEC 61000-4-2	\pm 4	kV



MECHANICAL

PARAMETER	SLEEVE BUSHING	BALL BEARING
Max. Acceleration	100000 rad/sec ²	100000 rad/sec ²
Max. Shaft Speed (mechanical)	100 RPM	10000 RPM
Typical Shaft Torque	0.5 in-oz (S -option) 0.3 in-oz (N -option)	0.05 in-oz
Max. Shaft Loading	2 lb. dynamic	2 lb.
Bearing Life	> 1000000 revolutions	$L_{10} = (90/F_r)^3$ * Where L_{10} = bearing life in millions of revs, and F_r = radial shaft loading in pounds
Weight	2.9 oz.	2.9 oz.
Max. Shaft Runout	0.0015 in, T.I.R.	0.0015 in, T.I.R.
Mounting Plate Screw Torque	4-6 in-lbs	4-6 in-lbs
Max. Panel Nut Tightening Torque	20 in-lbs	n/a
Technical Bulletin TB1001 - Shaft and Bore Tolerances	Download (https://www.usdigital.com/support/resources/reference/technical-docs/technical-bulletins/shaft-and-bore-tolerances-tb1001/)	

* only valid with negligible axial shaft loading.

ELECTRICAL

- Specifications apply over entire operating temperature range.
- Typical values are specified at Vcc = 12V and 25C.

Parameter	Min.	Typ.	Max.	Units
Supply Voltage	7.5	12	16	V
Supply Current @ 12V supply				
Active		14	18.5	mA
Sleep		2.5		
Analog Output Impedance		51		Ohms
Zero Scale Analog Voltage	0	2	12	mV
Full Scale Analog Voltage	4.066	4.095	4.124	V
Output Noise (Analog version)		10		mV rms
Differential Nonlinearity (Analog version)	-1.0		1.0	LSB
Integral Nonlinearity (Analog version)	-1.0		1.0	LSB
Absolute Accuracy (SEI interface version)		0.18	0.25	Degrees
Angle tracking speed				
Single-turn mode			3600	RPM
Multi-turn mode			1800	
Position Update Rate (1)			7	msec.

(1) The internal microcontroller takes a snapshot of the disk every 7 msec. and stores the position in memory. It responds immediately to a "report position request" by sending the most recently computed position.

DEFAULT SETTINGS

Parameter	Default value	Volatile?
SEI address	0	Non-volatile
Resolution	3600	Non-volatile
Origin offset	0	Non-volatile
Baud rate	9600	Volatile
Mode	0	(1)

(1) Mode is always restored from non-volatile EEPROM on power-up; however, there are separate SEI commands for setting the RAM copy only, or both the RAM copy and the non-volatile EEPROM copy. For an explanation of the Mode bits see SEI Absolute Encoder Communications Protocol (<https://www.usdigital.com/support/resources/reference/user-guides/sei-absolute-encoder-communications-protocol/>).

SEI NETWORK

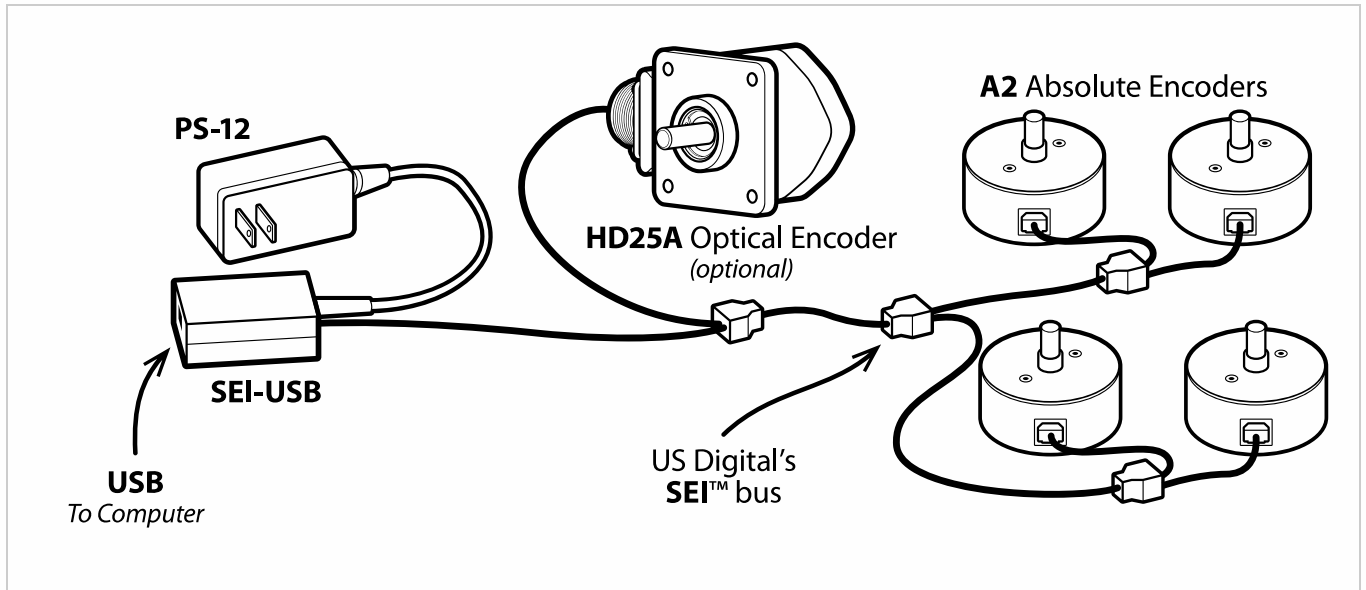

ANALOG OUTPUT

The analog version of the **A2** has a 12-bit DAC on the output which feeds to 2 lines that are otherwise used for the BUSY handshaking pair. This DAC has a full range of 0 to 4.095 Volts which is 1 mV per count. The absolute position value which the internal microcontroller sends to that DAC is the same as the digital value that it sends to the host over SEI. Since the resolution (which represents the number of codes per revolution) is field programmable, the range of the DAC will also follow that setup. The default resolution is 3600 codes per revolution which yields 1 count per a tenth of a degree. This makes the DAC output equal to 1 mV per tenth of a degree or 0 to 3.599 Volts. When the DAC needs to have the full range to 4.095 Volts, the single turn resolution should be set to 4096. This is easily done with the available software which runs on a PC. Cable CA-MD6A-SS-MD6-6FT and the SEI-USB

(<https://www.usdigital.com/products/accessories/interfaces/usb/sei-usb/>) adapter are needed to interface the **A2** analog version to a USB port or RS-232 serial COM port.

Please Note: The BUSY handshaking lines are replaced by the analog output option. This means that only one device will be able to be connected to the SEI (<https://www.usdigital.com/support/resources/reference/user-guides/sei-serial-encoder-interface-bus/>) bus when using the analog output option.



PIN-OUTS

PIN	DESCRIPTION
1	Ground
2	Busy+ Analog+
3	Busy- Analog-
4	Power
5	Data L
6	Data H

Notes

- Cables and connectors are not included and must be ordered separately.
- US Digital® warrants its products against defects in materials and workmanship for two years. See complete warranty (<https://www.usdigital.com/company/warranty>) for details.

Configuration Options

A2	-	Interface	-	Torque	-	Cover	-	Base	-	Housing
		A (Analog) S (SEI)		S (Default Torque) B (Ball Bearing) N (Light Static Drag)		D (Default) E (Extended)		D (Default) M (3" Diameter Bolt Circle)		D (Default)

PLEASE NOTE: This chart is for informational use only. Certain product configuration combinations are not available. Visit the A2 product page (<https://www.usdigital.com/products/A2>) for pricing and additional information.