

ED3 Rev. 1.91

Digital Encoder Display

Description:

The **ED3** is a digital LCD readout designed to display an encoder's incremental count values. The **ED3** features six digits and a sign to show negative values. The encoder input signals are filtered to ensure signal integrity over the entire input frequency range. An isolated SPDT relay output is provided to allow external switching as a function of encoder counts. Output relay closure can be defined to occur on encoder counts greater than, less than or equal to a specified count value. Power for the encoder (+5VDC) is supplied by the **ED3**. The **ED3** accepts power supply voltages of 7.5 to 30VDC range.

The **ED3** digital display has a window feature which activates the output relay over a range of counts determined by its high and low limits. This feature, when coupled with an encoder attached to a rotating shaft, allows the **ED3** to operate as a simple cam controller.

The user only needs to plug in the encoder and power supply. The **ED3** is shipped pre-configured to display an incremental encoder resolution of 360 CPR non-index. Configuration parameters may be easily changed from the default settings by means of the four front panel buttons.

The unit is constructed of a lightweight high impact polymer case with a clear viewing window. The **ED3** display offers 0.5" high digits with blue backlighting. The **ED3** front panel is waterproof when assembled into a panel. The panel thickness may range up to a maximum of 0.125" thick.

The **ED3** is available with either a single-ended (S) or a differential (D) encoder interface.

Features:

- Low cost
- Single-ended and differential inputs
- Large 0.5" high digits LCD with backlight
- Bidirectional count
- Count speeds up to 1.2MHz
- Programmable scaling factor
- Programmable decimal point
- Filtering of encoder signals
- Sealed front panel
- Operates from 7.5 to 30VDC
- Retains configuration when power is removed
- X1 or X4 count mode
- Front panel count reset button
- Accepts TTL quadrature and index signals
- Three LEDs show greater than, less than, window and match count conditions
- Actuates relay contacts for greater than, less than, window and match count conditions
- US Digital warrants its products against defects in materials and workmanship for two years. See complete warranty for details.

Electrical Specifications:

➤ Specifications apply over entire operating temperature range of 0 to 50°C.

Parameter	Min.	Typ.	Max.	Units
Supply Voltage	7.5	-	30	Volts
Supply Current*	-	-	40	mA
Encoder Input Cycle Frequency	-	-	1.2	MHz
Relay Contact Rating***	-	-	3.0	Amps
Relay Switching Rating****	-	-	125	VAC
	-	-	24	VDC
Relay Dielectric Strength	500	-	-	VAC
Relay Contact Resistance	-	-	100	Ohms
Encoder Output Voltage**	4.8	5.0	5.2	VDC
Encoder Supply Current	-	-	250	mA
Encoder Low Input	-	0.4	0.8	VDC
Encoder High Input	2.0	5.0	5.75	VDC

* Does not include current drawn from an external encoder.

** 100mA load.

*** At rated AC or DC voltage.

**** An external clamp diode should be used when switching inductive loads.

Operation Mode:

The **ED3** digital display has a dedicated encoder counter chip which is solely occupied with monitoring a single quadrature encoder input. The counter chip is configured in 1X count mode from the factory and can be easily switched to X4 count mode. This chip is capable of high speed counting and has filtering on the encoder input signals. The **ED3** has six display digits, which allows for a count range of -999999 to +999999. The scaling factor variable is used to translate encoder counts into a meaningful display value.

A preset button is provided on the **ED3** front panel to allow a user to reset the count value to zero; however, if zero is not included within the specified count range, then the count value is reset to the minimum count range value.

The isolated SPDT relay output is located on the **ED3** back panel and has three connections: common contacts, normally closed contacts and normally open contacts. The relay may be configured to activate on one of three encoder count conditions: greater than, less than, or match count.

Materials:

Housing	Polycarbonate
Front Window	Lexan

Operational Parameters:

Parameter	Min.	Max.
Encoder Resolution (CPR)	2	999999
Scale Factor	0.00001	999999
Count	-999999	999999
Less Than, Greater Than, Match Count	-999999	999999



ED3 Rev. 1.91

Digital Encoder Display

Pin-outs:

Pin	5-pin Single-ended	10-pin Differential Standard
1	Ground	Ground
2	Index	Ground
3	A channel	Index-
4	+5VDC power	Index+
5	B channel	A- channel
6		A+ channel
7		+5VDC power
8		+5VDC power
9		B- channel
10		B+ channel

Typical Input Circuits:

Differential:

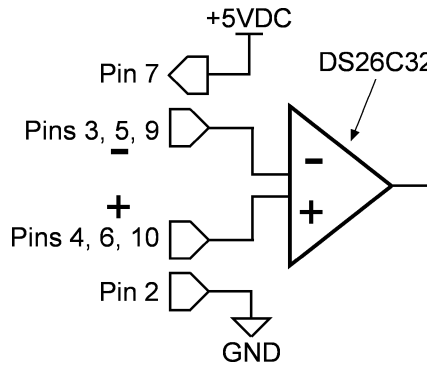

Single-ended:

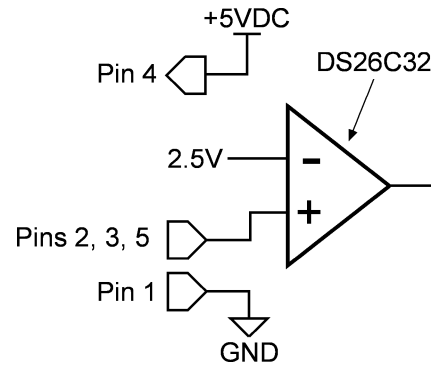

- > Rin, input resistance, = 6.8KOhms
- > Vin, common mode input range, = -7 to +7VDC
- > Vth, minimum differential input voltage, = ±200mV

Mechanical Drawing:

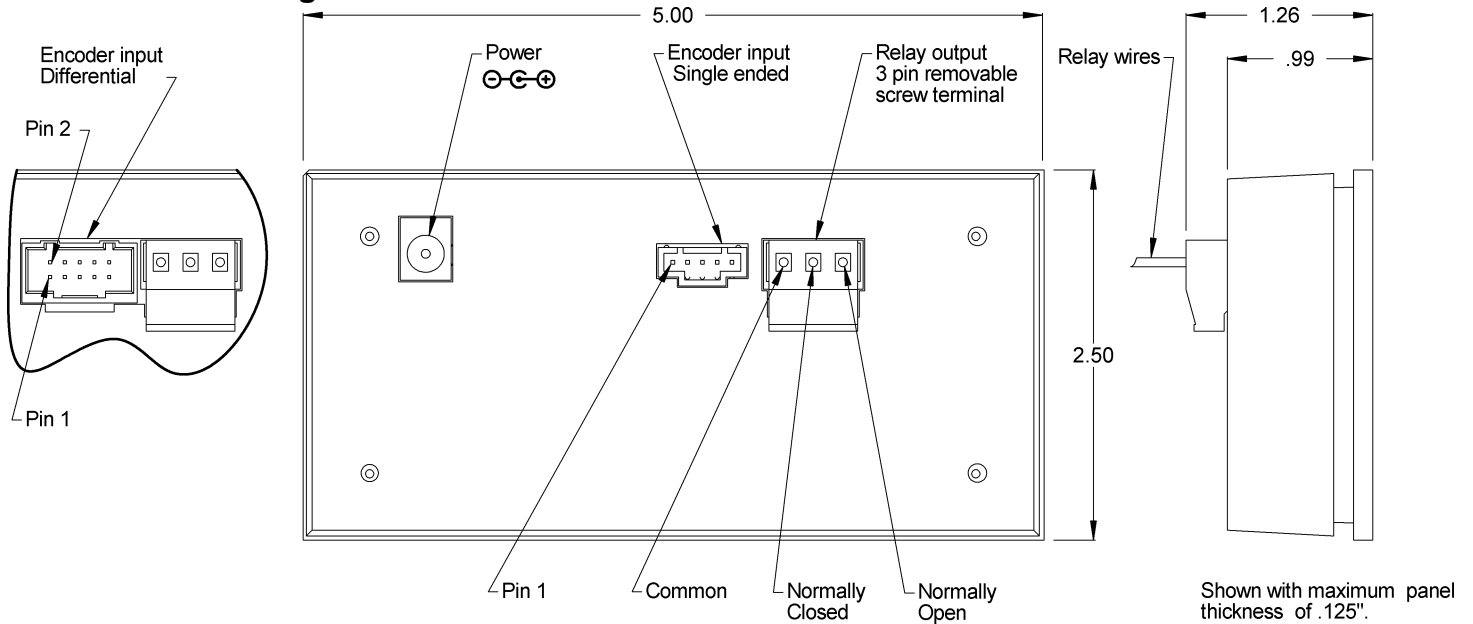

Panel Cutout Drawing:

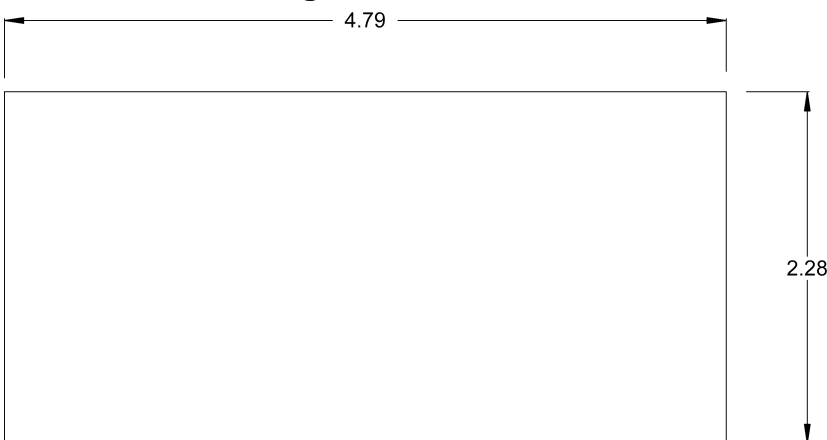

Installation Instructions:

- > Install in a panel with a thickness of up to 0.125".
- > Cut a rectangle in the panel: 4.79" wide by 2.28" tall.
- > Remove the 4 screws from the rear of the ED3.
- > Slowly pull apart the case.
- > Slide the front section of the display into the panel.
- > Slide the rear cover over the circuitry from the back side of the panel.
- > Re-install the screws.

ED3 Rev. 1.91

Digital Encoder Display

Configuration Mode:

All ED3 functions and variables are configured by means of the four front panel buttons. The buttons control different functions depending on the mode of the ED3: Configuration Mode or Operation Mode. Once in configuration mode, each button function is defined by the text or symbol just below the button.

To enter configuration mode, press the Menu button and hold it for approximately 3 seconds. The ED3 will then show a '1' in the left most digit of the display (see step 1), this represents step 1 of the eight step configuration sequence. Parameters are entered for each step by using the Decimal, Right Arrow and Up Arrow buttons. The Decimal button enables the decimal in any digit position, but is dependent on the scaling factor. The Right Arrow button moves the cursor one digit to the right. The Up Arrow button increments the active blinking digit from 0 to 9; the sign digit will display a negative sign when appropriate. Once a value is entered, press the Menu button to progress to the next step. Steps below are shown with default factory values.

For any step which may be a negative number, a value must first be entered before a minus sign can be applied.

Error Message: In firmware version 1.8 or later if there is a configuration conflict an error message will be displayed. For example, setting the Minimum Displayed Value higher than the Maximum Displayed Value. To check the firmware version, turn the unit off, hold down the Menu button then press the Power button. The firmware version number will flash on the screen.

When the ED3 is back in operation mode, the front panel button functions revert to the text located above each button.

Step 1 - Minimum Displayed Value: This step defines the minimum encoder count value to be displayed on the ED3. The minimum encoder count value may be zero, positive or negative and will be the smallest number displayed. If the encoder count value attempts to go below the minimum number, the ED3 counter will rollover to the maximum count value defined in step 3. Toggling the digit to the right of the step number digit with the Up Arrow key will enter a negative value.



Step Sign MSD LSD

Step 2 - Scaling Factor: This step allows a scaling factor value to be entered into the ED3 configuration. The scaling factor value is simply a number by which each encoder count is multiplied by to achieve a meaningful display value. In this step, placing a minus sign to the right of the step number digit reverses the increasing count direction of the encoder. The scaling factor value may be defined as a decimal number by activating the decimal point at any desired digit. **Please Note:** Do not use zero as the scale factor.



Step Sign MSD LSD

Step 3 - Maximum Displayed Value: This step defines the maximum encoder count value to be displayed on the ED3. If the encoder count value attempts to go above the maximum number, the ED3 will roll over to the minimum encoder count value defined in step 1.



Step Sign MSD LSD

Step 4 - Match Register: This step sets the value of the match register. When enabled (see step 7) the relay will be energized and the (continued above)



Step Sign MSD LSD

Match LED will be lit whenever the encoder count matches this value. The match register value may be either a positive or negative number.

Step 5 - Greater Than: This step sets the value of the greater than register. When enabled (see step 7) the relay will be energized and the High LED will be lit whenever the encoder count is greater than this value. The greater than register may be either a positive or negative number. In window mode, the relay energizes and the match LED comes on when the encoder count is less than or equal to this value, and the encoder count is greater than or equal to the value entered in step 6.



Step Sign MSD LSD

Step 6 - Less Than: This step sets the value of the less than register. When enabled (see step 7) the relay will be energized and the Low LED will be lit whenever the encoder count is less than this value. The less than register may be either a positive or negative number. In window mode, the relay energizes and the match LED comes on when the encoder count is greater than or equal to this value, but less than or equal to the value entered in step 5.



Step Sign MSD LSD

Step 7 - Relay, Encoder, Index and X1 / X4 Operation: This step affects the relay, encoder index and encoder X1 / X4 operation. The step will define which relay function is active by placing a '1' in the digit locations (see below). The display digits may be set to a '1' for active or '0' for inactive by using the Right Arrow and Up Arrow buttons. A single relay function may be enabled at any one time. If more than one relay function is enabled, the relay will not activate for any function. If a '1' is located in the right most digit, the ED3 display value will reset when an encoder index signal occurs. The ED3 can be placed in X1 / X4 counting modes by placing a '1' or a '0' in the digit defined below; a '1' will enable X4 counting mode, a '0' will enable X1 counting mode. The X1 mode counts 1 increment per cycle; the X4 mode counts 1 increment per 1/4 cycle. If a '1' is placed in the left most digit, the output relay of the ED3 will remain active over a range of counts determined by the high and low limits.

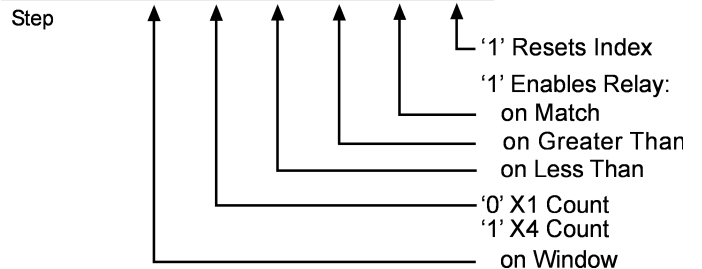
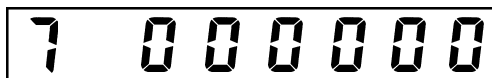

Step 8 - Memory: This step allows the data defined in the previous steps to be either entered into temporary memory, into non-volatile flash memory or to be canceled. The button below the 'E' will save the configuration settings into temporary memory. The button below the 'S' will save the configuration settings into non-volatile flash memory. The button below the 'C' will cancel all configuration settings. Pressing any of these three buttons will place the ED3 display back into operation mode. Step 1 will appear again if the Menu button is pressed in place of the E, S or C buttons while in this step.

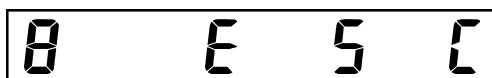

Step



info@usdigital.com ■ www.usdigital.com
 Local: 360.260.2468 ■ Sales: 800.736.0194
 Support: 360.397.9999 ■ Fax: 360.260.2469
 1400 NE 136th Ave. ■ Vancouver, Washington ■ 98684 ■ USA

ED3 Rev. 1.91

Digital Encoder Display

Programming Chart:

Initial Function	Button 1	Button 2	Button 3	Button 4
Step Number	MENU	DECIMAL	→	↑
	3 Sec.			
1	MINIMUM	Toggle Decimal	Move Right	Toggle Sign / Digits 0-9
2	SCALE FACTOR	Toggle Decimal	Move Right	Toggle Sign / Digits 0-9
3	MAXIMUM	Toggle Decimal	Move Right	Toggle Digits 0-9
4	MATCH	Toggle Decimal	Move Right	Toggle Sign / Digits 0-9
5	GREATER THAN	Toggle Decimal	Move Right	Toggle Sign / Digits 0-9
6	LESS THAN	Toggle Decimal	Move Right	Toggle Sign / Digits 0-9
7	RELAY, INDEX & X1/X4	-	Move Right	Toggle Digits 0-9
8	EXIT	Exit and Save in Temporary Memory	Exit and Save in Non-volatile Memory	Exit and Cancel

Compatible Cables & Connectors:

Finger-latching:		
5-pin	10-pin	Description
CON-FC5-22*	CON-FC10	Connector
CA-3133-1FT		Connector on one end with 4 12" wires
CA-3132-1FT		Connector on one end with 5 12" wires
CA-3131-6FT	CA-4217-6FT	Connector on one end of a 6' shielded round cable
CA-3620-6FT	CA-3619-6FT	Connectors on both ends of a 6' shielded round cable

* 22 AWG is standard. 24, 26 and 28 AWG are also available.

Attention:

- > Specify cable length when ordering.
- > Custom cable lengths are available. See the **Cables / Connectors** data sheet for more information.

Technical Data, Rev. 09.13.06, September 2006
All information subject to change without notice.

Ordering Information:

Price:
\$103.95 / 1
\$95.55 / 10
\$87.15 / 50
\$79.80 / 100

Part #:
ED3 - -

Interface:
S = Single-ended.
D = Differential.

Options:
NP = No power supply.

Cost Modifiers:

Add \$10 for **D**-interface.
Subtract \$5 for **NP**-option (no PS-12).

Includes:

> PS-12 (power supply).



info@usdigital.com ■ www.usdigital.com
Local: 360.260.2468 ■ Sales: 800.736.0194
Support: 360.397.9999 ■ Fax: 360.260.2469
1400 NE 136th Ave. ■ Vancouver, Washington ■ 98684 ■ USA