

Description

The ED3 is an LCD readout that serves as a position indicator or tachometer. The ED3 can display:

- Speed or position of a quadrature output incremental encoder
- Absolute position of a MA3-P/MAE3-P (PWM output) encoder
- Angle of a T5/T6/X3M inclinometer
- Number of digital pulse counts, or pulse rate, gated with a direction control

A 12VDC power supply (PS-12), that plugs directly into a 120VAC receptacle, is included with the display.



Features

- Seven 0.5" high numeric digits with blue backlight
- Bidirectional counting, displays signed values from 0.000001 to 9999999
- Three LEDs to indicate High, Match, or Low setpoints
- Isolated SPDT relay output with programmable set points
- Digitally filtered counting speed from 0 to 1.2MHz
- Easy in-the-field programming of modes and parameters
- Available with a single-ended (S) or a differential (D) interface
- Supplies +5V power for an external encoder or inclinometer
- Accepts power supply voltages from +7.5 to +24V

 **Panel Cutout Drawing**

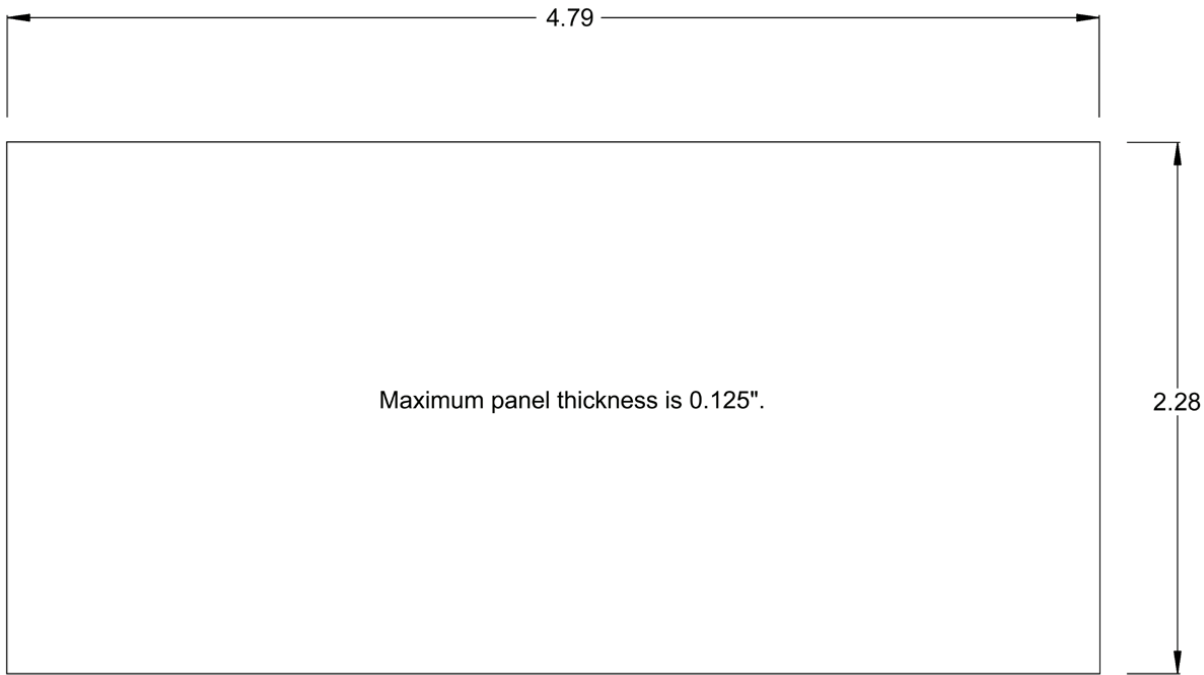

 **Mechanical Drawing**

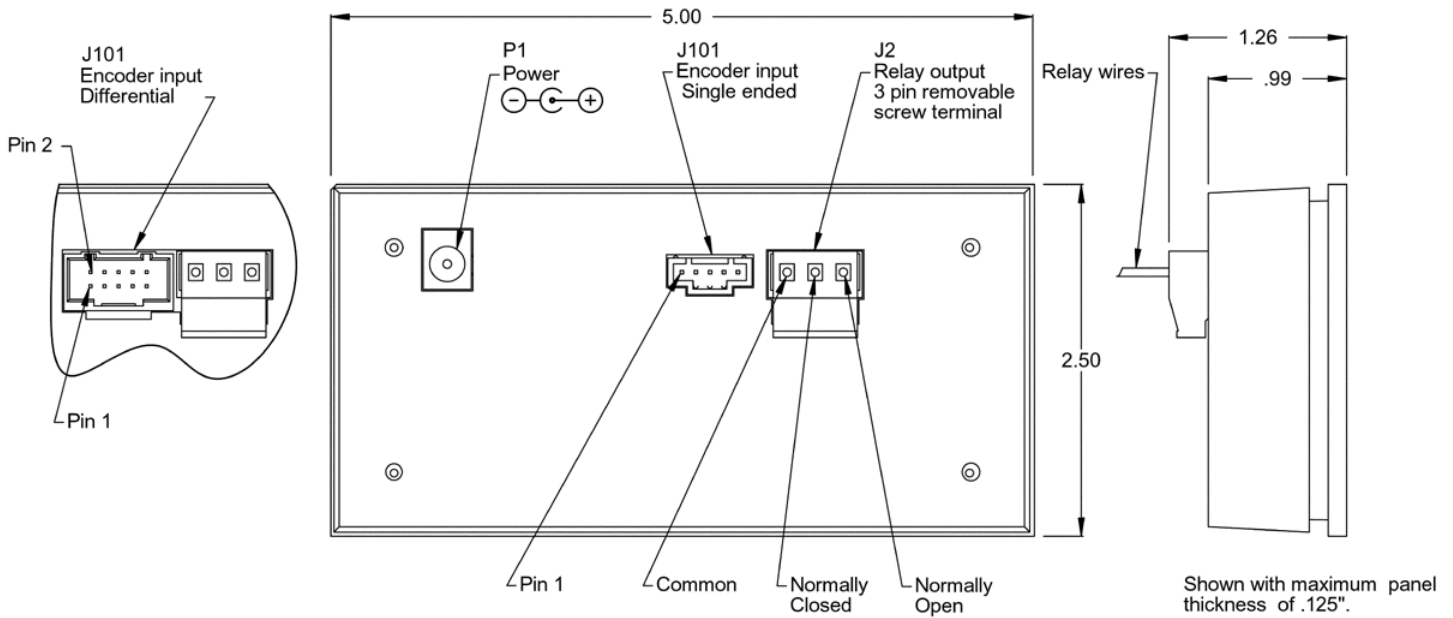

 **Applications**

- Quadrature Counter, Tachometer

- Up/Down Pulse Counter, Frequency Counter
- Position display
- Distance display
- Digital level display
- Speed zone alarm indicator
- Digital speed control
- Programmable tilt switch

Operational Parameters

Parameter	Min.	Max.
Encoder Resolution (CPR)	2	9999999
Scale Factor	0.000001	9999999
Count Range	-9999999	9999999
Display Resolution	0.000001	

Electrical

Specifications apply over entire operating temperature range of 0 to 50C.

Parameter	Min.	Typ.	Max.	Units
Supply Voltage Into ED3	+7.5	-	+24 (+18 rev. 2.10 and below)	Volts
Supply Current*				
With Backlight	-	-	40	mA
Without Backlight	-	-	25	mA
Encoder Input Cycle Frequency	0	-	1.2	MHz
Relay Contact Rating***	-	-	2.0	Amps
Relay Switching Rating****	-	-	125	VAC
	-	-	24	VDC
Relay Dielectric Strength	500	-	-	VAC
Relay Contact Resistance	-	-	0.1	Ohm
Output Voltage to Encoder**	4.8	5.0	5.2	VDC
Encoder Supply Current	-	-	250	mA
Encoder Single-ended Interface				
Low Input	-1.0	-	+2.1	VDC
High Input	+2.8	-	+7.0	VDC
Encoder Differential Interface				
Minimum Differential Voltage	200	-	-	mVDC
Common Mode Voltage	-7.0	-	+7.0	VDC

* Does not include current drawn from an external encoder.

** 100mA load.

*** At rated AC or DV voltage.

**** An external clamp diode should be used when switching inductive loads.

Operating Mode

In normal operating mode, the function of each button is defined by the label located just above the button. When the **ED3** first powers up, a Tachometer or Counter Mode label is briefly displayed to indicate the currently configured operating mode.

The display will flash 9999999 for numbers that are outside of the configured limits of the **ED3**.

Preload:

In Counter Mode, the encoder index signal, if enabled, or the preset button, if enabled, can preset the display to a *preload* parameter value.

In Tachometer Mode, if enabled, when the preset button is pressed, the velocities at that instant will be stored as target velocities and the display is set to zero. That target will thereafter be subtracted from the current velocities to display the relative difference above and below that target. Pressing and holding the preset button for three seconds will return to the normal mode of displaying the actual velocities.

Relay:

The internal isolated SPDT relay with field programmable set points is useful for controlling external devices.

In Counter Mode, the **ED3** can be configured to activate on one of four conditions: greater than, less than, window, or match count.

In Tachometer Mode, the **ED3** can be configured to activate on one of three encoder velocity conditions: greater than, less than, or between.

LEDs:

The **High LED** turns on when the displayed value is greater than the **Hi Set** parameter.

The **Low LED** turns on when the displayed value is less than the **Lo Set** parameter.

In Counter Mode, if the relay is set to the **Match** condition, the **Match LED** turns on when the displayed value is equal to the **Match** parameter. If the relay is set to the **Between** condition, the **Match LED** turns on when the displayed value is between the **Hi Set** and **Lo Set** parameters.

In Tachometer Mode, if the relay is set to the **Between** condition, the **Match LED** turns on when the displayed value is between the **Hi Set** and **Lo Set** parameters.

Factory Default Configuration

Counter Mode (default mode)

Scale Factor:	1
Lo Count (Minimum Number to Display):	0

Counter Mode (default mode)

Hi Count (Maximum Number to Display):	359
= Set (Match):	180
Hi Set:	180
Lo Set:	180
Relay:	No
Quad (Quadrature Mode):	1
Ind (Index Enable):	Off
Pre (Preset Button Enable):	On
Preload Value:	0
Lite (Backlight Default Setting):	Off

Tachometer Mode

Dis (Display Tachometer Units):	rp60
CPR (Encoder Resolution):	500
Lo Set:	1
Hi Set:	100
Relay:	No
Quad (Quadrature Mode):	1
Abs (Absolute Value Mode):	On
Pre (Preset Button Enable):	On
Lite (Backlight Default Setting):	Off

Configuration Mode

The operating mode and parameters may be changed by pressing and holding the **Menu** button for 3 seconds; this will place the **ED3** into Configuration Mode. In Configuration Mode, the function of each button is defined by the text or symbol below it:

- **Menu Button:** Press (without holding) to scroll through the modes or parameters to change.
- **Decimal Button:** Enables or disables the decimal point of numeric values at the current cursor position.
- **Right Arrow Button:** Moves the cursor to the right one digit at a time when a numeric parameter is selected.
- **Up Arrow Button:** Scrolls through the available values for the selected parameter.

The **ED3** has two sets of parameter tables, one for Counter Mode and one for Tachometer Mode. Changing the Counter Mode parameters does not affect the Tachometer Mode parameters and vice versa. Saved parameters can be either viewed or changed. Upon entering Configuration Mode, the **Menu** button scrolls through the two mode choices: Tach or Counter. Press the **Up Arrow** button to select the desired mode. The **ED3** will then present the first parameter for that mode. Parameters are explained in detail in the *Menu Settings* section of this data sheet.

Please Note:

- The far left digit of the display is the sign digit.

- › Entering a negative Scale parameter is equivalent to reversing the direction of the encoder or inclinometer.
- › The displayed resolution is rounded (not truncated) to the range resolution defined by the Lo Count/Hi Count or Lo Set/Hi Set parameters. See these parameter settings for details.

Configuration Mode may be exited at any time by pressing and holding the Menu button for three seconds. The following exit menu choices will be displayed:

- › SAVE Yes - Changes are saved permanently to nonvolatile memory.
- › SAVE No - All changes are abandoned.
- › SAVE TST - Changes are saved to RAM only for as long as the ED3 remains powered on.

Press the **Up Arrow** to scroll through the exit choices. Press the **Menu** button to execute the exit choice.

All parameters are checked when an attempt is made to save the configuration parameters. If a non-valid entry is detected, an error code (below) is displayed and must be corrected before the settings can be saved.

- › **Error 1** - Counter Mode range error: **The Lo Count** is set higher than **Hi Count**.
- › **Error 2** - Tachometer Mode parameter error: The **Lo Set** is set higher than the **Hi Set**.
- › **Error 3** - The **Scale Value** parameter is set to zero. The ED3 will always display zero. Set the **Scale Value** parameter to a non-zero number.
- › **Error 4** - **PreLoad** count value is outside the **Lo Count** and **Hi Count** range.

Typical Input Circuit

Single-ended:

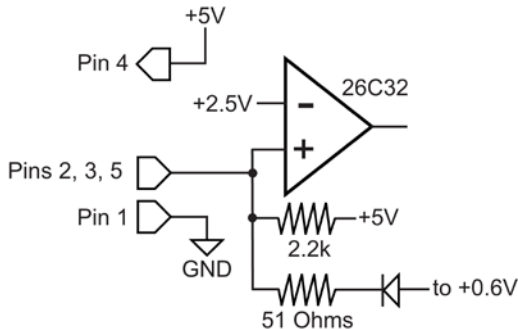

Differential:

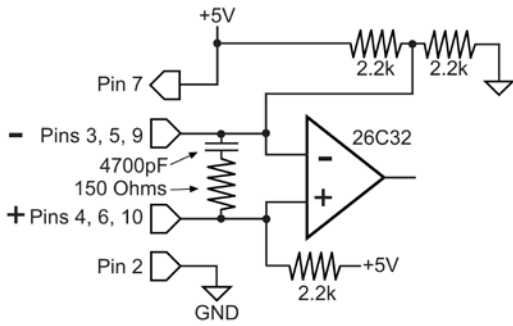

Counter Menu Settings

SCALE

Scale Factor

The internal counter values are multiplied by this factor to display numbers in more meaningful user units. A negative scale factor (minus sign in the left-most digit) will reverse the count direction. A decimal point may be placed by using the Decimal and Right Arrow buttons. Use any non-zero number.

NOTE: The **Scale Factor** resolution has no effect on the displayed resolution. For the PWM encoders, the **Scale Factor** selection is limited to +1 or -1; the sign will reverse the count direction.

Lo Count

Lo Count (Minimum Number to Display)

The valid display range of the ED3 is set by the Lo Count and Hi Count parameters. The Lo Count defines the smallest number to be displayed. Any positive, negative, decimal, or integer number may be entered. If the displayed number attempts to go below Lo Count, the ED3 counter will rollover to the maximum number defined by Hi Count.

NOTE: Placement of the decimal point in **Hi Count** or **Lo Count** controls the number of decimal digits actually displayed during operation. The **Hi Count** or **Lo Count** resolution can't be set any finer than the **Scale Factor** resolution.

Hi Count

Hi Count (Maximum Number to Display)

The valid display range of the ED3 is set by the Lo Count and Hi Count parameters. The Hi Count defines the largest number to be displayed. Any positive, negative, decimal, or integer number may be entered. If the displayed number attempts to go above Hi Count, the ED3 counter will rollover to the minimum number defined by Lo Count. Hi Count must be a greater number than Lo Count.

NOTE: Placement of the decimal point in **Hi Count** or **Lo Count** controls the number of decimal digits displayed during operation. The **Hi Count** or **Lo Count** resolution can't be set any finer than the **Scale Factor** resolution.



= Set (Match)

The Match LED will be lit whenever the display number matches this value. If the Relay Mode is set to = (Match), the Relay will be energized. Any positive, negative, decimal, or integer number may be entered. To disable the match condition, set =Set outside of the display range (Hi Count).



Hi Set

The High LED will be lit whenever the display number is greater than this value. If the Relay Mode is set to Hi, the Relay will be energized. If the Relay Mode is set to Bt (Between), the Relay will be energized and the Match LED will light when the display number is \geq Lo Set and \leq Hi Set. To disable this condition, set Hi Set greater than the display range ($>$ Hi Count).



Lo Set

The Low LED will be lit whenever the display number is less than this value. If the Relay Mode is set to Lo, the Relay will be energized. If the Relay Mode is set to Bt (Between), the Relay will be energized and the Match LED will light when the display number is \geq Lo Set and \leq Hi Set. To disable this condition, set Lo Set less than the display range ($<$ Lo Count).

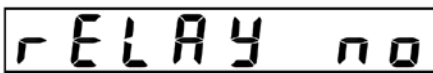

Relay

The relay can be energized when the following conditions occur:

- **No** Never
- **Hi** When the display number is $>$ Hi Set
- **Lo** When the display number is $<$ Lo Set
- **Bt** (Between) When the display number is \geq Lo Set and \leq Hi Set
- **=** When the display number is equal to =Set (Match)



Mode

The following choices are available:

- › Quad 1
- › Quad 2
- › Quad 4
- › Step Dir (Step and Direction)
- › P-Ratio

Quad 1 will cause the ED3 to count once per quadrature cycle (X1 mode), **Quad 2** will count twice per quadrature cycle (X2 Mode) and **Quad 4** will count four times per quadrature cycle (X4 mode). **Step Dir** will count digital pulses at input A; the count direction is controlled by input B (B=0 selects up count, B=1 selects down count - Input B may switch state only when input A = 1). **P-Ratio** will enable the device to read a PWM input.

Example: If the ED3 receives 360 quadrature cycles, Quad 1 will generate 360 increments, Quad 4 will generate 1440 increments.

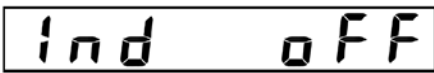

Ind (Index Enable)

When an index input is asserted to a high logic level, this parameter provides the following choices:

- › **On**: Preset the displayed value to the PreLoad parameter.
- › **Off**: Ignore the index input.

Note: This parameter does not apply to PWM encoders.

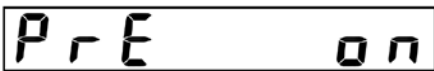

Pre (Preset Button Enable)

When the Preset Button is pressed, this parameter provides the following choice:

- › **On**: Preset the displayed value to the PreLoad parameter.
- › **Off**: Ignore the Preset Button.



Preload Value

The displayed value will be changed to this value when the preset button is enabled and asserted, or the index signal is enabled and asserted. Any positive, negative, decimal, or integer number may be entered. Be sure to enter a value \geq Lo Count and \leq Hi Count.

L I T E o F F

Lite (Backlight Default Setting)

When the ED3 first powers on, the backlight will automatically be turned on if this parameter is set to On, or Off if this parameter is set to Off. This parameter does not affect the front panel backlight button. It is always enabled and will toggle the backlight on or off.

 **Tachometer Menu Settings**

d 1 5 r P 6 0

Dis (Display Tachometer Units)

Four tachometer display units can be selected:

- › RP60 (RPM) Revolutions per Minute
- › RP1 (RPS) Revolutions per Second
- › CP60 (CPM) Counts per Minute
- › CP1 (CPS) Counts per Second

C P r

CPR

Enter the resolution (CPR) of the external encoder, full quadrature cycles per revolution. This must be a positive integer value.

S C A L E

Scale Factor

Set this number to 1 if the encoder to shaft ratio is 1:1, the encoder resolution has been entered, and the above units are desired. Other values can be entered for other situations such as compensation for gearing between the shaft and the encoder. The velocity is multiplied by this factor to display numbers in more meaningful user units.

A negative scale factor (minus sign in the left-most digit) will reverse the displayed velocity. If desired, a decimal point may be placed by using the Decimal and Right Arrow buttons. Use any non-zero number.

NOTE: The **Scale Factor** resolution has no effect on the displayed resolution.

HI SET

Hi Set

The High LED will be lit whenever the display velocity is greater than this value. If the Relay Mode is set to Hi, the Relay will be energized. If the Relay Mode is set to Bt (Between), the Relay will be energized and the Match LED will light when the display velocity is \geq Lo Set and \leq Hi Set. To disable this condition, set Hi Set greater than the highest attainable velocity.

NOTE: Placement of the decimal point in *Hi Set* or *Lo Set* controls the number of decimal digits displayed during operation. The *Hi Set* or *Lo Set* resolution can't be set any finer than the *Scale Factor* resolution. Encoder CPR and requested display resolution will affect the display update time.

Lo SET

Lo Set

The Low LED will be lit whenever the display velocity is less than this value. If the Relay Mode is set to Lo, the Relay will be energized. If the Relay Mode is set to Bt (Between), the Relay will be energized and the Match LED will light when the display velocity is \geq Lo Set and \leq Hi Set. To disable this condition, set Lo Set less than the lowest attainable (or negative) velocity.

NOTE: Placement of the decimal point in *Hi Set* or *Lo Set* controls the number of decimal digits displayed during operation. The *Hi Set* or *Lo Set* resolution can't be set any finer than the *Scale Factor* resolution. Encoder CPR and requested display resolution will affect the display update time.

RELAY no

Relay

The relay can be energized when the following conditions occur:

- **No** Never
- **Hi** When the display number is $>$ Hi Set
- **Lo** When the display number is $<$ Lo Set
- **Bt** (Between) - When the display number is \geq Lo Set and \leq Hi Set

QuAd 1

Mode

The following Mode choices are available:

- Quad 1
- Quad 2

- › Quad 4
- › Step Dir (Step and Direction)

Quad 1 will cause the ED3 to count once per quadrature cycle (X1 mode), **Quad 2** will count twice per quadrature cycle (X2 Mode) and **Quad 4** will count four times per quadrature cycle (X4 mode). The **Step Dir** mode will accept non-quadrature pulses on the A input; the count direction is controlled by the B input (Input B may switch state only when input A = 1). The Step Dir mode is only valid when the CP1 and CP60 display output is selected.

Examples: If the ED3 receives 360 quadrature cycles, Quad 1 will generate 360 increments, Quad 4 will generate 1440 increments. In the Counts-Per-Time modes (CP1, CP60), the displayed rotational velocity in Quad 4 will be 4 times that of Quad 1; in the Revolutions-Per-Time modes (RP1, RP60), the displayed velocity will be calculated using Quad 4 mode only (other counting modes are ignored).

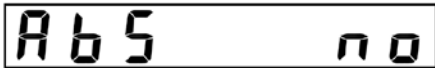

Abs (Absolute Value Mode)

The "Yes" selection will display all velocities as positive numbers regardless of the shaft direction. The "No" selection will display positive velocities in one direction and negative in the other.

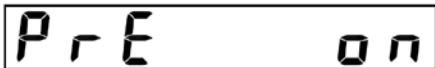

Pre (Preset Button Enable)

When the preset button is pressed the velocities at that instant will be stored as target velocities and the display set to zero. That target will thereafter be subtracted from the current velocities to display the relative difference above and below that target. Pressing and holding the preset button for three seconds will return to the normal mode of displaying the actual velocities.

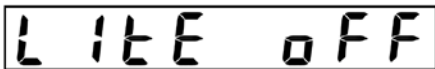

Lite (Backlight Default Setting)

When the ED3 first powers on, the backlight will automatically be turned on if this parameter is set to On, or Off if this parameter is set to Off. This parameter does not affect the front panel backlight button. It is always enabled and will toggle the backlight on or off.

 **Programming Chart**

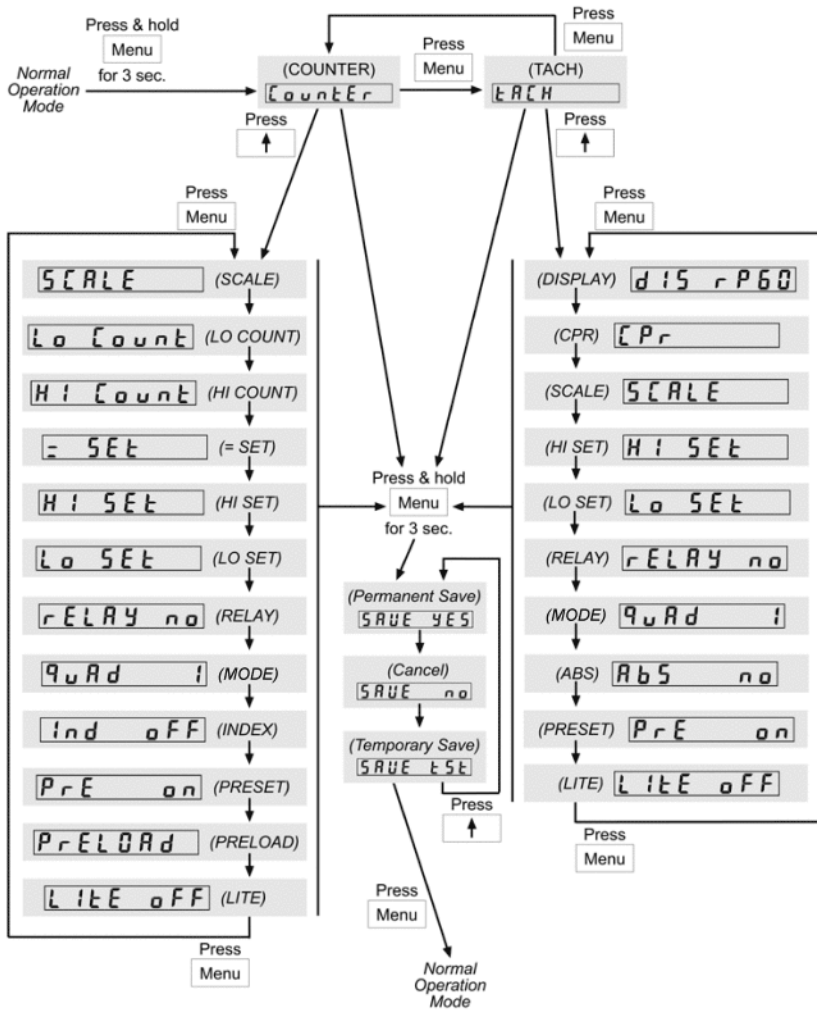

Installation Instructions

- › Remove the rear cover by removing the four screws in the back.
- › Insert the display through the rectangular opening in the front panel so that the gasket seals against the front.
- › Reassemble the rear cover to secure the display into the front panel.

Materials

Housing	Glass filled polycarbonate
Front Window	Lexan

J101 Pin-outs

Pin	5-pin Single-Ended	10-pin Differential
1	Ground	Ground
2	Index	Ground
3	A channel	Index-
4	+5VDC power	Index+
5	B channel	A- channel
6		A+ channel
7		+5VDC power
8		+5VDC power
9		B- channel
10		B+ channel

Firmware Version

To view the firmware version of the **ED3**, use the following steps:

- Turn the unit off.
- While holding down the Menu button, turn the unit back on by pressing the Power button.
- Firmware version number will flash on screen for a few seconds until unit enters normal operation mode.

REV. 1.91 and older firmware

The documents below are provided for informational purposes only.
 Rev. 1.91 is no longer available and has been replaced with Rev. 2.20.

[Rev 1.91 PDF Data Sheet](#)

Ordering Information

ED3 -

Input

S = *Single-ended*

D = *Differential*

Notes

- US Digital warrants its products against defects in materials and workmanship for two years. See complete warranty for details.

Base Pricing

Quantity	Price
1	\$119.50
10	\$102.72
50	\$90.85
100	\$81.60

▸ Add \$10.00 per unit for **Input** of Differential