

Description

These flexible servo couplings are designed to connect two shafts that may be misaligned or have axial movement and relieve the stresses that would otherwise result from a rigid coupling. This design has been tested in excess of MIL-HDBK-5A, rotating beam, fatigue data for 2024T4 QQA-225/6. This military specification indicates that if a beam is flexed through a controlled arc (our maximum misalignment rating) for six million cycles, it has reached a point on the fatigue curve that indicates that the coupling will have infinite life. Hysteresis and lost motion is eliminated by the six short beam design. They are suitable for encoders, resolvers and motor drives.



Features

- ▶ Zero backlash
- ▶ Zero hysteresis
- ▶ Minimum wind-up
- ▶ Six beam design
- ▶ Split clamp design
- ▶ High torque
- ▶ Infinite life
- ▶ One piece aluminum design

Mechanical Drawing

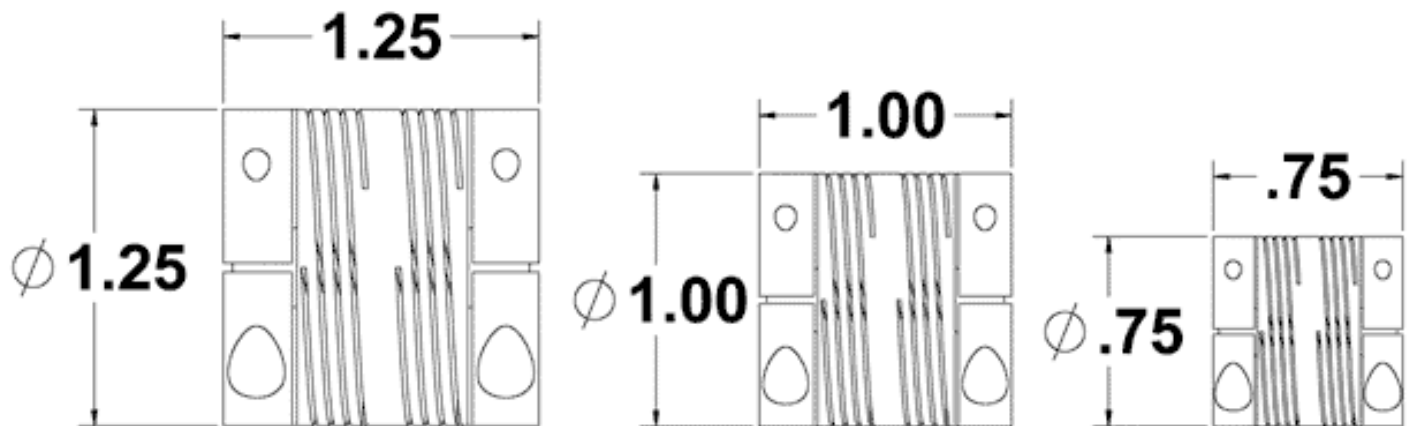

Mechanical

Shafts may extend into the flexible area because the ID in the flexible area is larger than the clamp ID. Clamps are an integral part of the coupling and cannot be removed.

The correct dynamic torque safety factor should be determined by the customer in accordance with acceleration, deceleration, reversals or sudden stops, etc.

Coupling material is QQA25/6 2024-T3.51 aluminum with MIL-A8625 Type II black anodize.

OD	ID1 (1)	ID2 (1)	Max. Torque (2)	Windup(3)	Max. Angular Offset	Max. Parallel Offset	Max. Axial Motion	Clamp Screw Size
0.75"	.250"	.250"	20 lb-in	.66 arcmin/(oz-in)	5 °	.008"	.005"	2-56
0.75"	.250"	5mm	24 lb-in	.54 arcmin/(oz-in)	5 °	.008"	.005"	2-56
1"	.250"	.250"	55 lb-in	.25 arcmin/(oz-in)	5 °	.010"	.010"	4-40
1"	.375"	.375"	42 lb-in	.35 arcmin/(oz-in)	5 °	.010"	.010"	4-40
1.25"	.250"	.250"	120 lb-in	.12 arcmin/(oz-in)	5 °	.010"	.010"	6-32
1.25"	.375"	.375"	103 lb-in	.24 arcmin/(oz-in)	5 °	.010"	.010"	6-32

(1) Bore diameters are +.001" -.000".

(2) Maximum torque includes both static and dynamic torque. It should not be exceeded by the peak acceleration and deceleration forces encountered during sudden stops or reversals.

(3) Torque and Windup (Torsion spring rate) tests are measured at maximum misalignment.

Installation Tips

- › Clean the shaft so it is free of oil and grease.
- › Slip the coupling onto the shaft.
- › Tap on the coupling so it find its natural length (not stretched or compressed).
- › Tighten the screws using a hex wrench. Max wrench torque is 6 inch pounds (3/4" OD) and 10 inch pounds (1" OD).
- › Be sure light can be seen between the beams.

Ordering Information

FC -	<input type="text"/>	-	<input type="text"/>	-	<input type="text"/>
	OD		ID1		ID2
	750 = 0.75"		250 = 0.25"		197 = 5mm
	1000 = 1"		375 = 0.375"		250 = 0.25"
	1250 = 1.25"				375 = 0.375"

Rules

- ID1 must be equal to 250 when OD is equal to 750
- ID2 must be something other than 375 when OD is equal to 750
- ID2 must be something other than 375 when ID1 is equal to 250
- ID2 must be something other than 197 when OD is something other than 750
- ID2 must be equal to 375 when ID1 is equal to 375

Notes

- US Digital warrants its products against defects in materials and workmanship for two years. See complete warranty for details.

Base Pricing

Quantity	Price
1	\$39.95
10	\$34.01
50	\$29.91
100	\$28.61