



S16 Features

- Small size (16mm OD)
- Low Cost
- Snap-in polarized connector
- 250/256 to 4,000/4096 cycles per revolution (CPR)
- 1,000/1024 to 16000/16384 pulses per revolution (PPR)
- Single +5V supply



S16 Product Description

The S16 16mm micro-optical shaft encoder is designed to provide A, B, and Index digital quadrature signals for high volume restricted space applications. The S16 encoder is available with either a bushing or ball bearing system for high speed applications. The shaft torque is designed to provide the feel of a potentiometer for front-panel manual interfaces. The S16 series encoder is connected using a 5-conductor, polarized, 0.8mm pitch connector (Hirose part number DF52-5P-0.8C). The mating cable (see the Cables web page) is not included and is available separately.



Mechanical Drawings

S16 Micro Optical Shaft Encoder

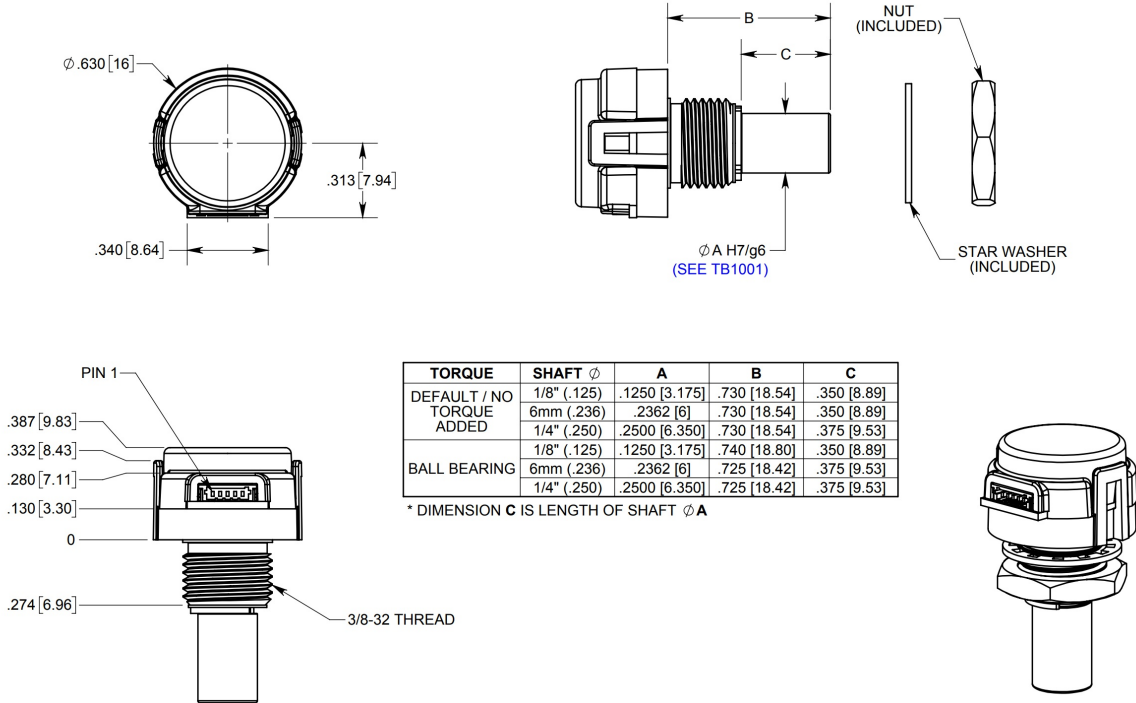

RELEASE DATE: 03/30/2021

US DIGITAL 1400 NE 136th Avenue
Vancouver, Washington 98684, USA

info@usdigital.com
sales@usdigital.com
support@usdigital.com

Local: 360.260.2468
Toll-free: 800.736.0194

UNITS: INCHES [MM]
METRIC SHOWN FOR REFERENCE ONLY

Specifications

ENVIRONMENTAL

PARAMETER	VALUE	UNITS
Operating Temperature	-40 to 100	C
Electrostatic Discharge, IEC 61000-4-2	±12	kV
Vibration (10Hz to 2kHz, sinusoidal)	20	G
Shock (6 milliseconds, half-sine)	75	G



MECHANICAL

SPECIFICATION	SLEEVE BUSHING	BALL BEARING
Max. Acceleration	10000 rad/sec ²	250000 rad/sec ²
Max. Shaft Speed (1) (mechanical)	100 RPM	15000 RPM
Max. Shaft Torque	0.5 ±0.2 in-oz (D-option) 0.3 in-oz (N-option)	0.05 in-oz
Max. Shaft Loading	2 lbs. dynamic 20 lbs. static	1 lb.
Bearing Life	> 1000000 revolutions	$L_{10} = (22/F_r)^3 *$ Where L_{10} = bearing life in millions of revs, and F_r = radial shaft loading in pounds
Weight	0.48 oz.	0.43 oz.
Max. Shaft Runout	0.0015 in. T.I.R.	0.0015 in. T.I.R.
Max. Panel Nut Tightening Torque	20 in-lbs	20 in-lbs
Technical Bulletin TB1001 - Shaft and Bore Tolerances	Download (https://www.usdigital.com/support/resources/reference/technical-docs/technical-bulletins/shaft-and-bore-tolerances-tb1001/)	

* Only valid with negligible axial shaft loading.

(1) The maximum speed due to electrical considerations is dependent on the CPR. See the E16 (<https://www.usdigital.com/products/encoders/incremental/kit/e16/>) product page.



ELECTRICAL

PARAMETER	MIN.	TYP.	MAX.	UNITS	NOTES
Supply Voltage	4.5	5.0	5.5	V	
Supply Current		18	26	mA	no load
Low-level Output			0.4	V	$I_{OL} = 4 \text{ mA}$, $V_{CC} = 5V$
		0.1		V	no load
High-level Output	4.7			V	$I_{OH} = 4 \text{ mA}$, $V_{CC} = 5V$
		4.9		V	no load
Output Rise Time		80	135	ns	no load
Output Fall Time		80	135	ns	no load
Maximum Output Frequency					
250/256 CPR	0.2			MHz	
500/512 CPR	0.4			MHz	
1,000/1,024 CPR	0.8			MHz	
2,000/2,048 CPR	1.6			MHz	
4,000/4,096 CPR	1.85			MHz	

PHASE RELATIONSHIP

- Specifications apply over the entire operating temperature range.
- Values are for the worst error over full rotation.
- Refer to the timing diagram below.

PARAMETER	SYMBOL	MIN.	TYP.	MAX.	UNITS
Symmetry	X, Y	150	180	210	$^{\circ}e$ <i>(https://www.usdigital.com/support/resources/glossary/#glossary_e)</i>
Quadrature	Z	60	90	120	$^{\circ}e$ <i>(https://www.usdigital.com/support/resources/glossary/#glossary_e)</i>
Index Pulse Width	Po	60	90	120	$^{\circ}e$ <i>(https://www.usdigital.com/support/resources/glossary/#glossary_e)</i>
Ch. I Rise After Ch. B or Ch. A Fall	t1		10		ns
Ch. I Fall After Ch. B or Ch. A Rise	t2		10		ns

TIMING DIAGRAM

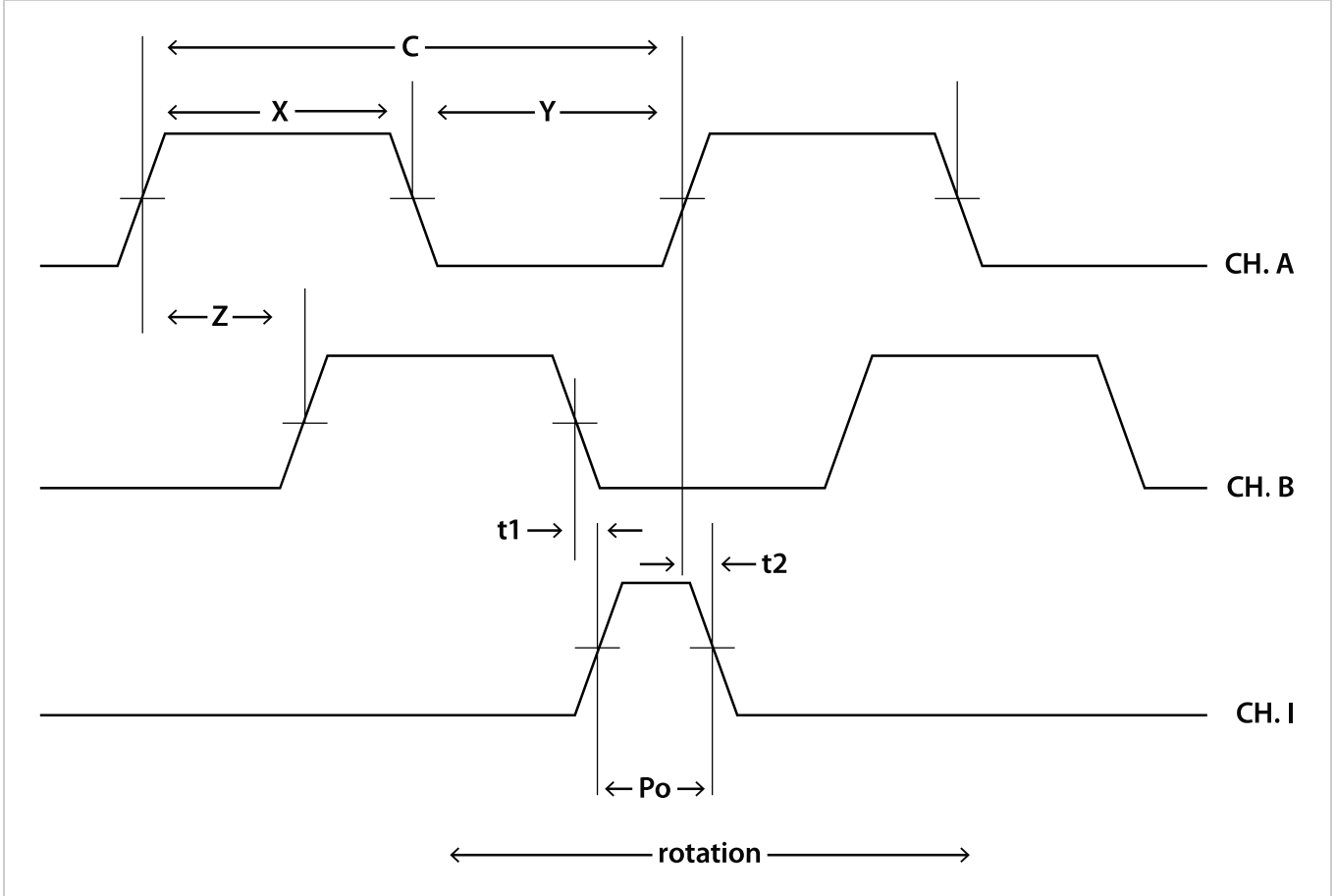

B leads A for clockwise shaft rotation, and A leads B for counterclockwise rotation viewed from the shaft side of the encoder.

PIN-OUT

PIN	DESCRIPTION
1	Ground
2	Index
3	A channel
4	+5VDC power
5	B channel

Notes

- US Digital® warrants its products against defects in materials and workmanship for two years. See complete warranty (<https://www.usdigital.com/company/warranty>) for details.
- Cables and connectors are not included and must be ordered separately.
- For ordering information please configure the product and you'll see the Compatible Cables / Connectors section above.



Configuration Options

S16	CPR (Cycles Per Revolution)	Shaft Diameter	Output	Torque
	250	125 (1/8")	S (Single-Ended)	D (Default Torque)
	256	236 (6mm)		B (Ball Bearing)
	500	250 (1/4")		N (Light Static Drag)
	512			
	1000			
	1024			
	2000			
	2048			
	4000			
	4096			

PLEASE NOTE: This chart is for informational use only. Certain product configuration combinations are not available. Visit the S16 product page (<https://www.usdigital.com/products/S16>) for pricing and additional information.